

DO NOT SCALE

NOTES

1. ALL DIMENSIONS IN MILLIMETRES UNLESS OTHERWISE STATED.
2. WHEN THE COVER FROM THE TOP OF THE GULLY CONNECTION TO FINISHED LEVEL IS LESS THAN 1200 WITHIN THE CARRIAGEWAY AND 900 IN THE VERGE, THEN A CLASS Z 150 BED AND SURROUND SHOULD BE PROVIDED TO THE GULLY CONNECTIONS.
3. GULLIES AND CONNECTIONS TO BE IN ACCORDANCE WITH CL 508.3
4. ALL GULLY GRATINGS TO INCORPORATE A 'NON-ROCK' FEATURE.
5. GULLY GRATING TO BE SET 15mm BELOW FINISHED CARRIAGEWAY LEVEL AT THE BACK AND SET 5mm BELOW FINISHED CARRIAGEWAY LEVEL AT THE FRONT.

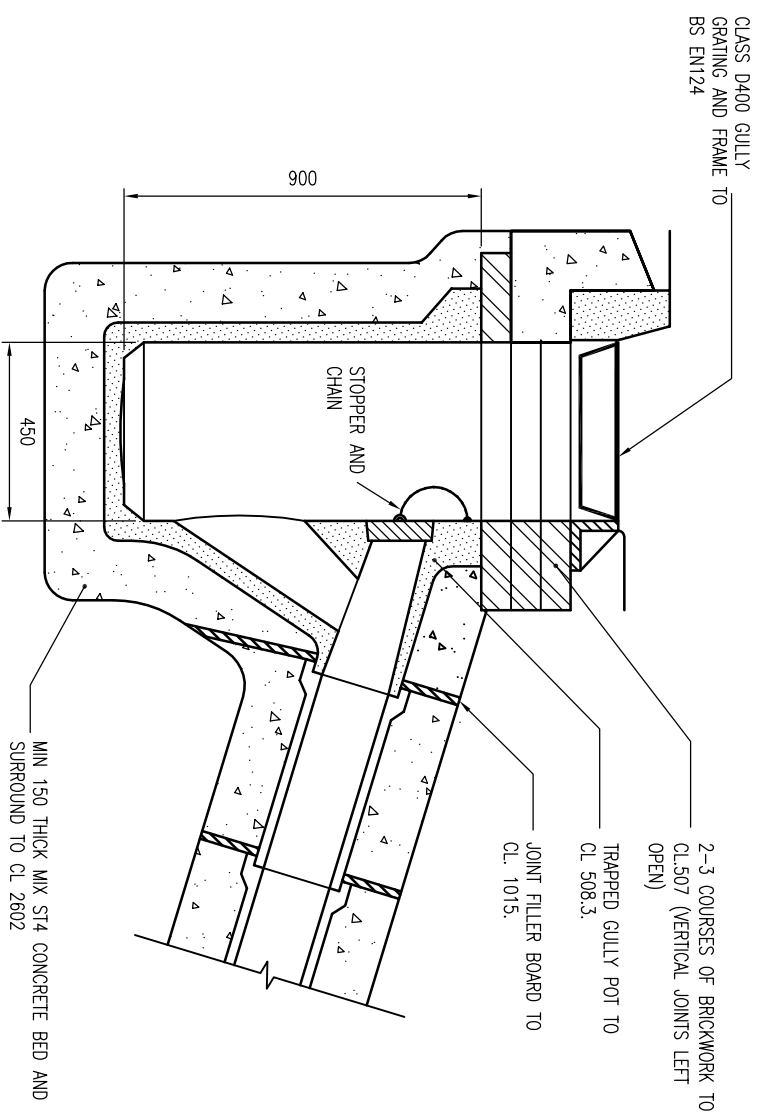

TRAPPED GULLY WITH SPIGOT OUTLET

REV	DATE	BY	DESCRIPTION	CHK	APP
C	18/02/10	JH	OCC COMMENTS INCORPORATED	JMH	JH
B	03/12/08	JH	ISSUED FOR TECHNICAL APPROVAL	JMH	JH
A	30/05/08	PJ	FIRST ISSUE	LH	JM

DRAWING STATUS:
FOR TECHNICAL APPROVAL



Mountbatten House, Basing View, Basingstoke, Hampshire RG21 4HU
Tel: +44 (0)1256 318800 Fax: +44 (0)1256 318700
<http://www.wspgroup.com>

CLIENT:
COUNTRYSIDE PROPERTIES

ARCHITECT:

PROJECT:
**SOUTH WEST BICESTER
BICESTER, OXFORDSHIRE**

TITLE:
**ON SITE WORKS
TRAPPED ROAD GULLY POT DETAIL**

SCALE @ A3:
1:20

CAD FILE:
1903-SD-102

DESIGNER/DRW: PJ
DATE: January 2008

PROJECT No: 11011903
DRAWING No: 1903/SD/102
REV: C

ALL CLAUSE NUMBERS REFER TO SPECIFICATIONS FOR HIGHWAY WORKS.