







| | | | |
|---|--------------------|---|--------------------|
|  | DIAG. 610 |  | PLAN INSERT |
|  | DIAG. 610 REVERSED |  | DIAG. 606 |
|  | DIAG. 611 |  | DIAG. 606 REVERSED |

DIAGRAM NUMBERS REFER TO THE TRAFFIC SIGNS REGULATIONS AND GENERAL DIRECTIONS 2002.



PLAN VIEW

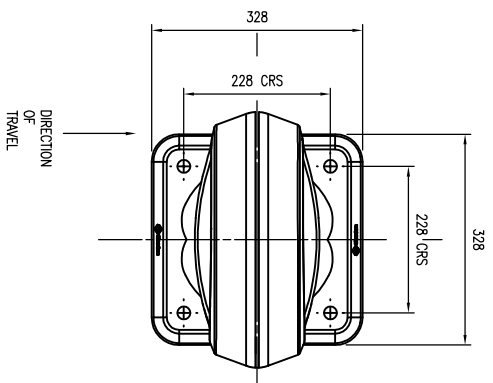
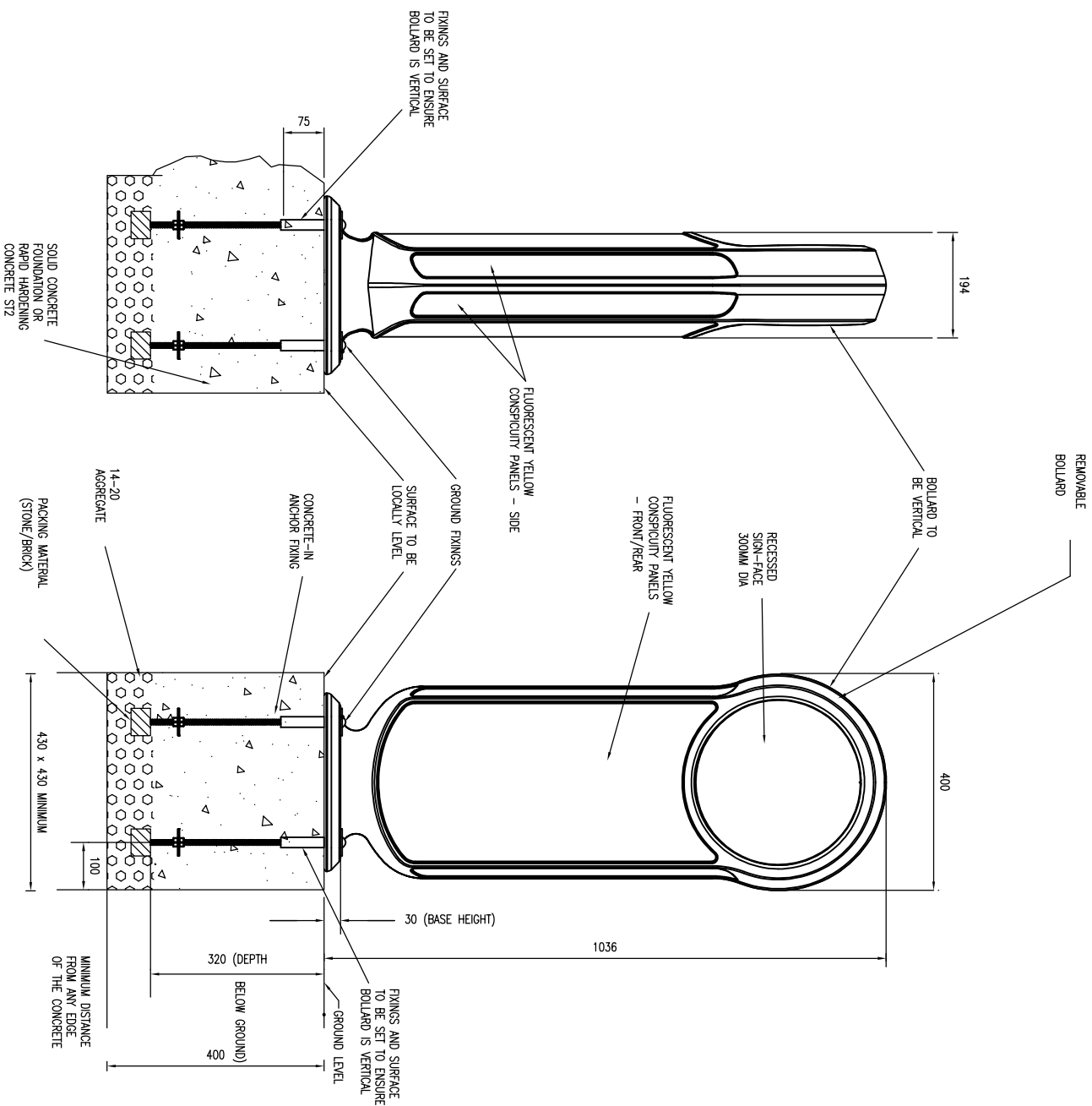

SIDE VIEW

FRONT VIEW

DO NOT SCALE

NOTES:

1. ALL DIMENSIONS ARE IN MILLIMETRES.
2. ENSURE TRAFFIC SIGN FACE SIDE IS ORIENTATED CORRECTLY AND FACING ONCOMING TRAFFIC.
3. CONTACT WITH HOT BITUMINOUS MATERIALS IS TO BE AVOIDED AS BOLLARD PERFORMANCE WILL BE SERIOUSLY IMPAIRED.
4. STANDARD INSTALLATION WITH GRADE S12 RAPID HARDENING CONCRETE AS SPECIFIED BY THE ENGINEER.
5. BOLLARD SIGN FACES AS SPECIFIED BY THE ENGINEER.
6. BOLLARD COLOUR AS SPECIFIED BY THE ENGINEER.

| REV | DATE | BY | DESCRIPTION | CHK | APP |
|-----|----------|----|-------------------------------|-----|-----|
| C | 03/12/08 | JH | ISSUED FOR TECHNICAL APPROVAL | JM | JH |
| B | 28/05/08 | JH | AMENDMENTS TO DETAIL | LH | JM |
| A | 11/03/08 | PJ | FIRST ISSUE | LH | JM |

DRAWING STATUS:
FOR TECHNICAL APPROVAL



Mountbatten House, Basing View, Basingstoke, Hampshire RG21 4HU
Tel: +44 (0)1256 318800 Fax: +44 (0)1256 318700
<http://www.wspgroup.com>

CLIENT:
COUNTRYSIDE PROPERTIES

ARCHITECT:

PROJECT:
**SOUTH WEST BICESTER
BICESTER, OXFORDSHIRE**

TITLE:
**ON SITE WORKS
GLADSON REBOUND BOLLARD**

| | | |
|-------------------------|----------------------------|---------------------|
| SCALE @ A3 N.T.S. | CHECKED: LH | APPROVED: JM |
| CD/FILE 1903-SD-216 | DESIGN/DRAWN: PJ | DATE: March 2008 |
| PROJECT No: 11011903 | DRAWING No: 1903/SD/216 | REV: C |

© WSP Group plc