

DO NOT SCALE

NOTES:

1. ALL DIMENSIONS ARE IN MILLIMETRES UNLESS OTHERWISE STATED.
2. ALL CLAUSE NUMBERS REFER TO THE SPECIFICATION FOR HIGHWAY WORKS, LATEST EDITION.
3. FOUNDATIONS TO BE MIX ST2 CONCRETE
4. ALL SIGNING SHALL ACCORD WITH THE TRAFFIC SIGNS REGULATIONS AND GENERAL DIRECTIONS 2002.
5. LOCATION OF SIGNING SHALL BE WITHIN THE ADOPTED HIGHWAY. EXACT LOCATIONS SHALL BE AGREED WITH THE ENGINEER ON SITE PRIOR TO PREPARATION OF FOUNDATIONS/EXCAVATIONS AND SIGN ERECTION.
6. PRIOR TO PLACING THE CONCRETE THE CONTRACTOR SHALL ENSURE THAT SIGN POSTS ARE VERTICAL AND CORRECTLY ORIENTATED.
7. SIGNS SHALL ONLY BE FITTED AFTER ERECTION AND CONCRETING OF POSTS.
8. FOR DETAILS OF SIGN SIZES, MOUNTING HEIGHTS, ILLUMINATION REQUIREMENTS, POSTS, FOUNDATIONS AND MATERIALS SEE SIGN SCHEDULES.

REV	DATE	BY	DESCRIPTION	CHK	APP
C	03/12/08	JH	ISSUED FOR TECHNICAL APPROVAL	JAM	GH
B	30/05/08	JH	AMENDMENTS TO DETAIL	LH	JM
A	28/05/08	PJ	FIRST ISSUE	LH	JM

FOR TECHNICAL APPROVAL

DRAWING STATUS:

WSP

Mountbatten House, Basing View, Basingstoke, Hampshire RG21 4HU
 Tel: +44 (0)1256 318800 Fax: +44 (0)1256 318700
<http://www.wspgroup.com>

COUNTRYSIDE PROPERTIES

CLIENT: COUNTRYSIDE PROPERTIES
 ARCHITECT: SOUTH WEST BICESTER BICESTER, OXFORDSHIRE

PROJECT: SOUTH WEST BICESTER BICESTER, OXFORDSHIRE

TITLE: ON SITE WORKS TYPICAL SIGN MOUNTING DETAILS

SCALE @ A3: N.T.S.

CHECKED: LH	APPROVED: JM
-------------	--------------

CAD FILE: 1903-SD-215	DESIGN/DRAWN: PJ	DATE: January 2008
-----------------------	------------------	--------------------

PROJECT No: 11011903	DRAWING No: 1903/SD/215	REV: C
----------------------	-------------------------	--------

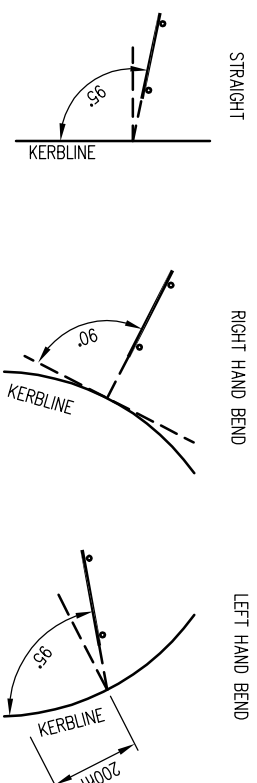
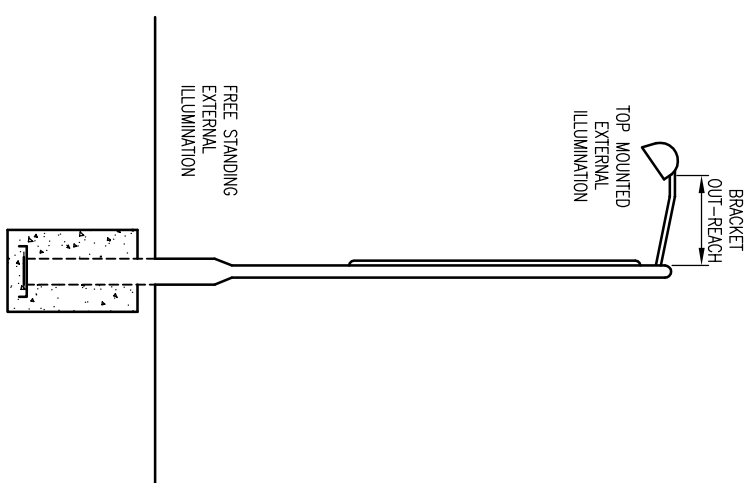

ORIENTATION OF SIGN TO AVOID SPECULAR REFLECTION

TYPICAL SIGN MOUNTING DETAIL

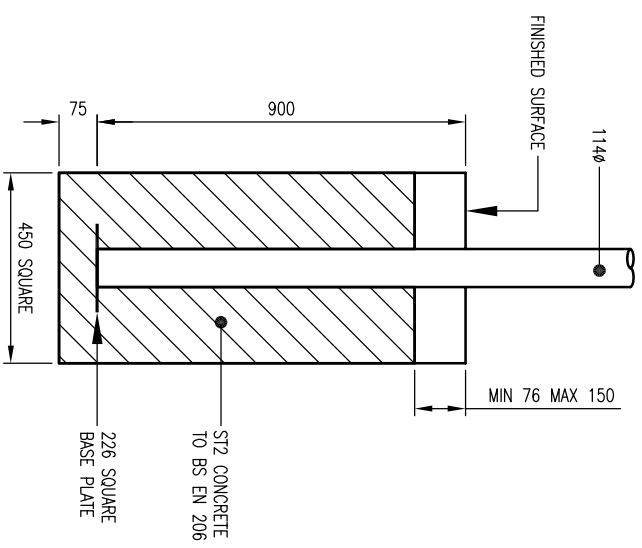
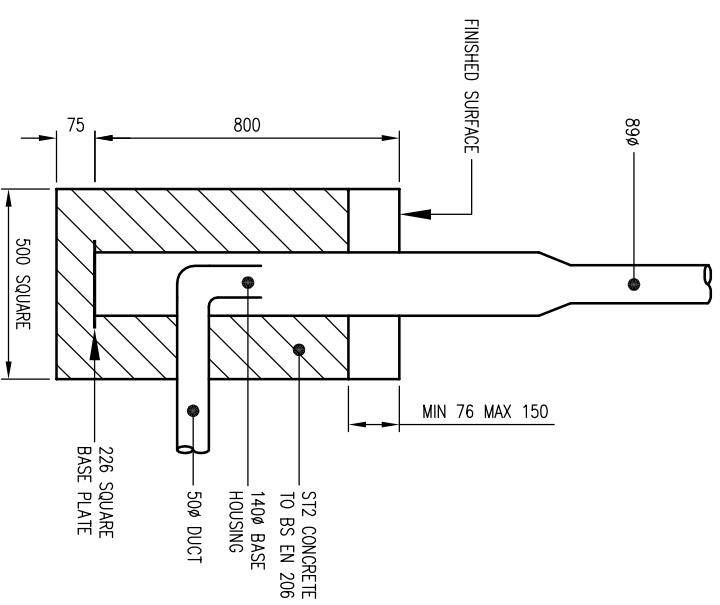
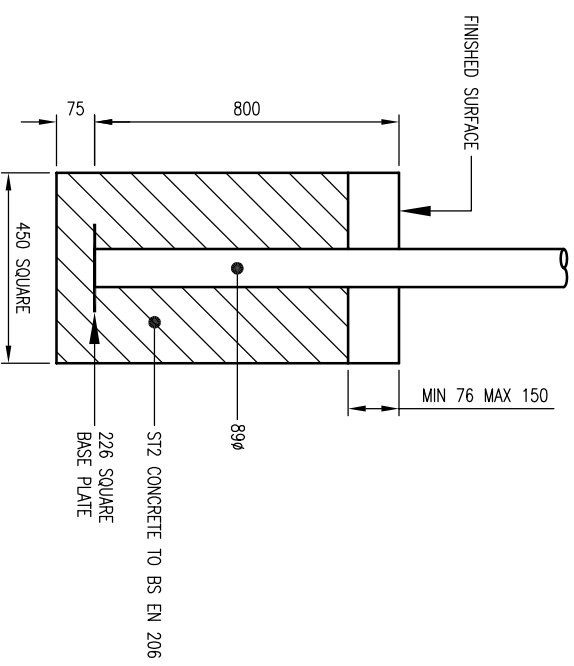

TUBULAR SECTION POSTS

CONCRETE BASES FOR SIGN POSTS

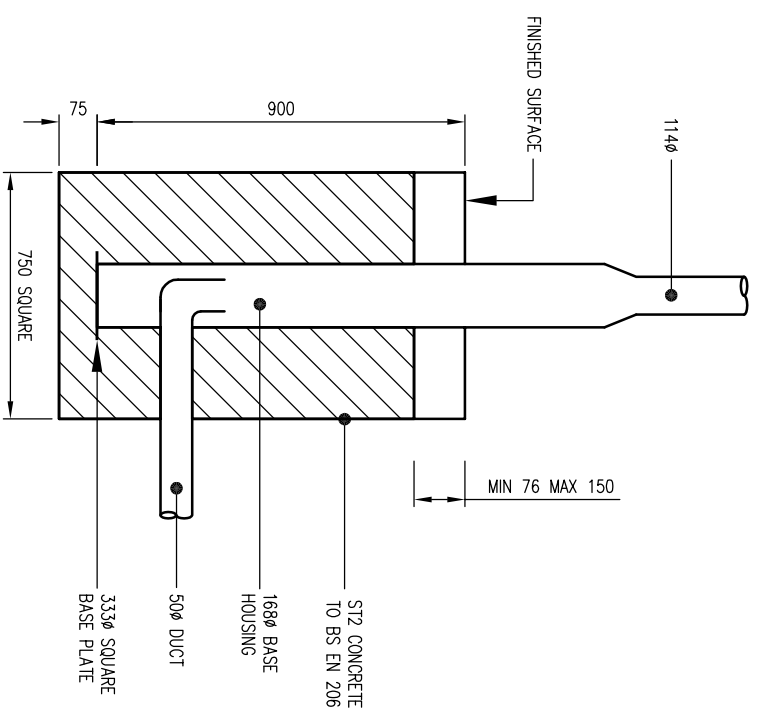

TUBULAR SECTION POSTS WITH BASE HOUSING