

- NOTES:
1. ALL DIMENSIONS ARE IN MILLIMETRES UNLESS OTHERWISE STATED.
 2. ALL CLAUSE NUMBERS REFER TO THE SPECIFICATION FOR HIGHWAY WORKS (SHW), LATEST EDITION.
 3. ALL PRECAST CONCRETE UNITS ARE TO CONFORM TO AND BE LAID IN ACCORDANCE WITH CL.1101 OF THE SPECIFICATION FOR HIGHWAY WORKS LATEST EDITION.

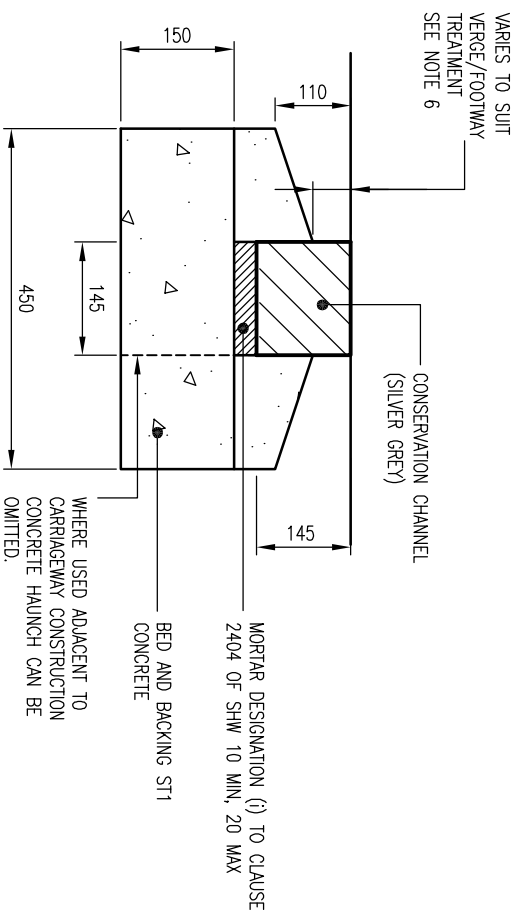

CONSERVATION CHANNEL (SQUARE) TYPE CK2

VARIES TO SUIT VERGE/FOOTWAY TREATMENT SEE NOTE 6

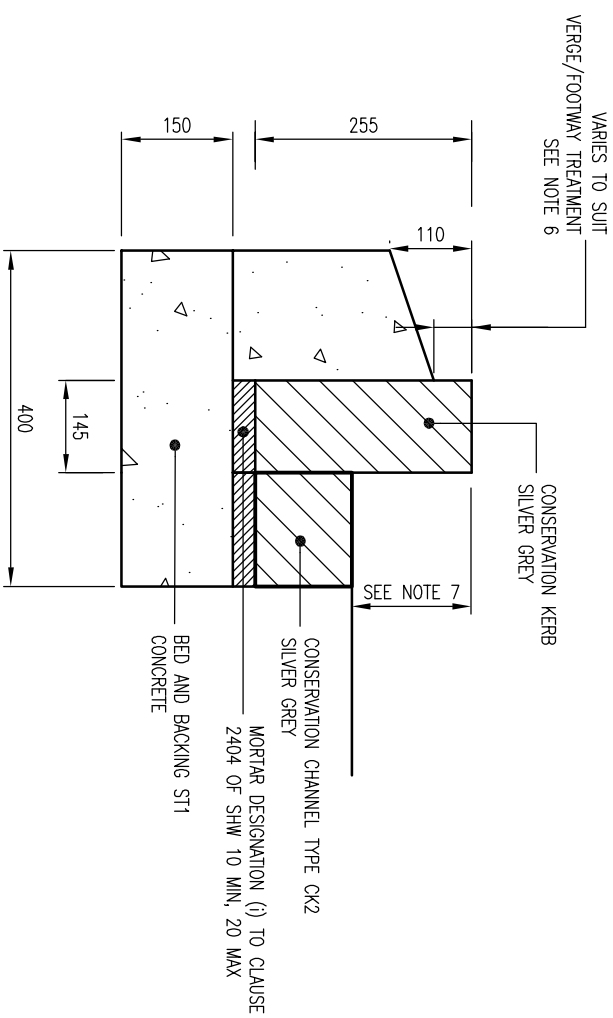

CONSERVATION KERB AND CHANNEL (CKC)

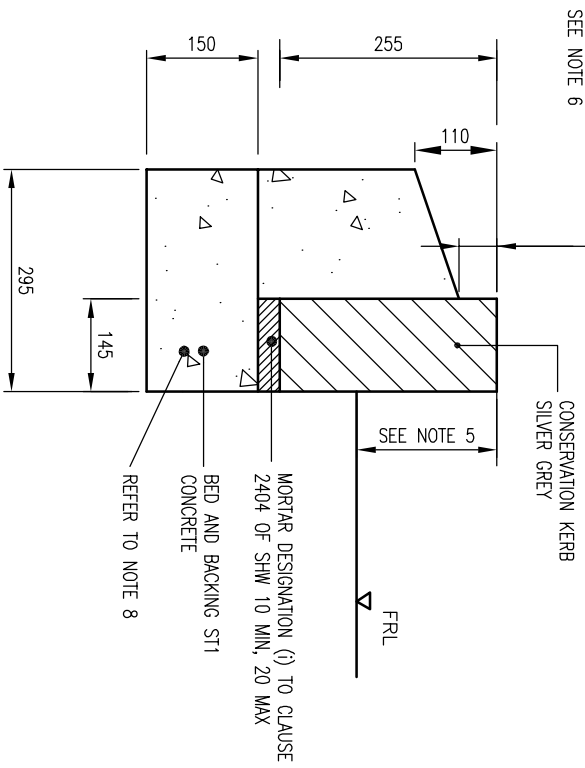

CONSERVATION KERB (CK)

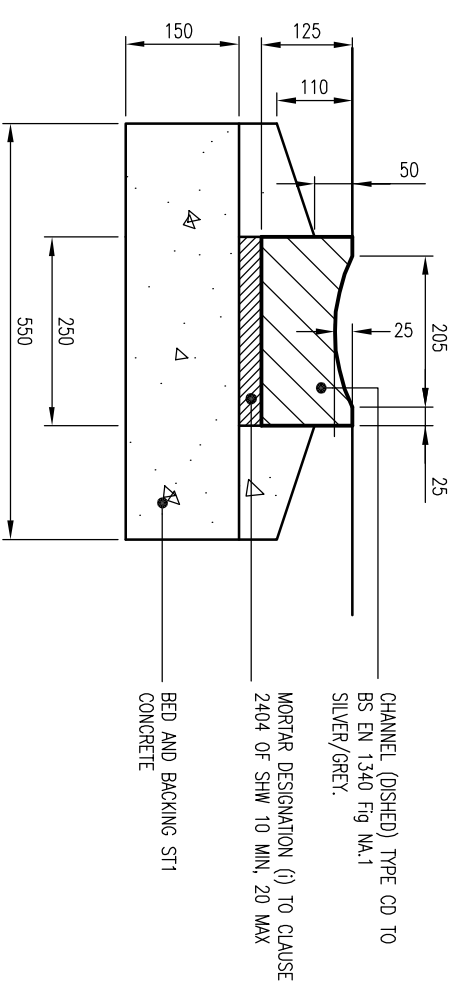

CHANNEL (DISHED) TYPE CD

NOTES:

DO NOT SCALE

4. KERB, BED AND BACKING SHALL BE ST1 GRADE CONCRETE TO CL.2602 OF THE SHW, LATEST EDITION.
5. MECHANICAL HANDLING OF HEAVY ITEMS IS RECOMMENDED
- STANDARD PCC HB2 KERBS 69KG
- CONSERVATION KERB 83KG
- STANDARD PCC EDGING 45KG
6. TO BE 30mm WHEN ADJACENT TO THE GRASSED VERGE, AND 30mm PLUS THE DEPTH OF THE PAVING STONE WHEN ADJACENT TO PAVING STONES.
7. CONSERVATION KERB FACE (CK) TO BE 160mm HIGH UNLESS OTHERWISE INDICATED.
8. FOR CONSERVATION KERB (CK) LOCATED AT ENDS OF CENTRAL RESERVATION (SPINE ROAD A 0/0.000-420.000 INSTALL WITH 10 MM OPEN GAPS FOR DRAINAGE. ALSO LEAVE OPENING IN BACKING AT JOINT.

REV	DATE	BY	DESCRIPTION	CHK	APP
D	08/01/09	DP	TEXT AND NOTE AMENDMENTS	JM	PH
C	12/12/08	JH	ISSUED FOR TECHNICAL APPROVAL	JM	PH
B	30/05/08	JH	MINOR AMENDMENTS	LH	JM
A	11/03/08	PJ	FIRST ISSUE	LH	JM

DRAWING STATUS: FOR TECHNICAL APPROVAL



Mountbatten House, Basing View, Basingstoke, Hampshire RG21 4HU
 Tel: +44 (0)1256 318800 Fax: +44 (0)1256 318700
<http://www.wspgroup.com>

CLIENT: COUNTRYSIDE PROPERTIES

ARCHITECT:

PROJECT: SOUTH WEST BICESTER
 BICESTER, OXFORDSHIRE

TITLE: ON SITE WORKS
 KERB TYPES SHEET 2 OF 3

SCALE @ A3: 1:10
 CHECKED: LH
 APPROVED: JM

DATE: January 2008

PROJECT No: 11011903
 DRAWING No: 1903/SD/211
 REV: D