

BULLNOSED KERB TYPE BN

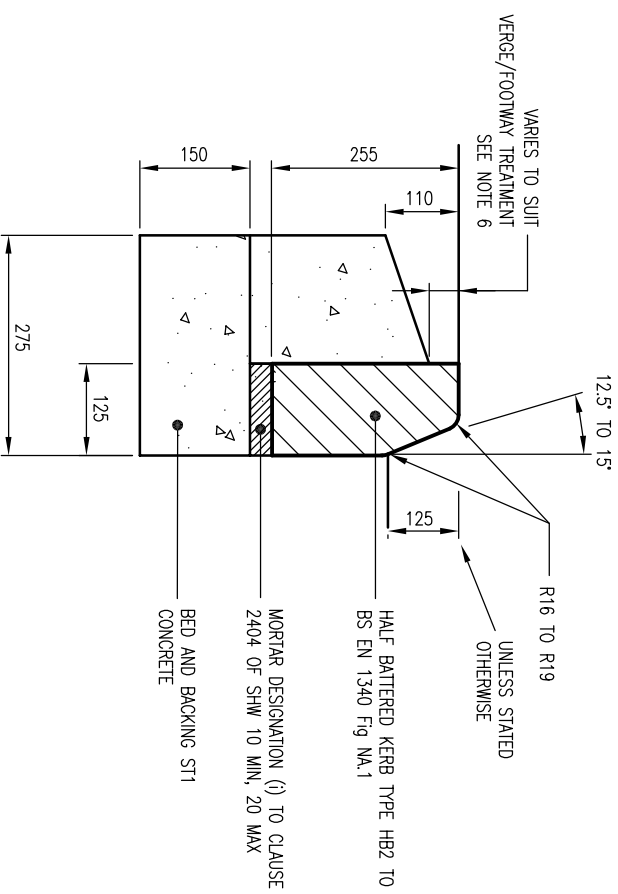

HALF BATTERED KERB TYPE HB2

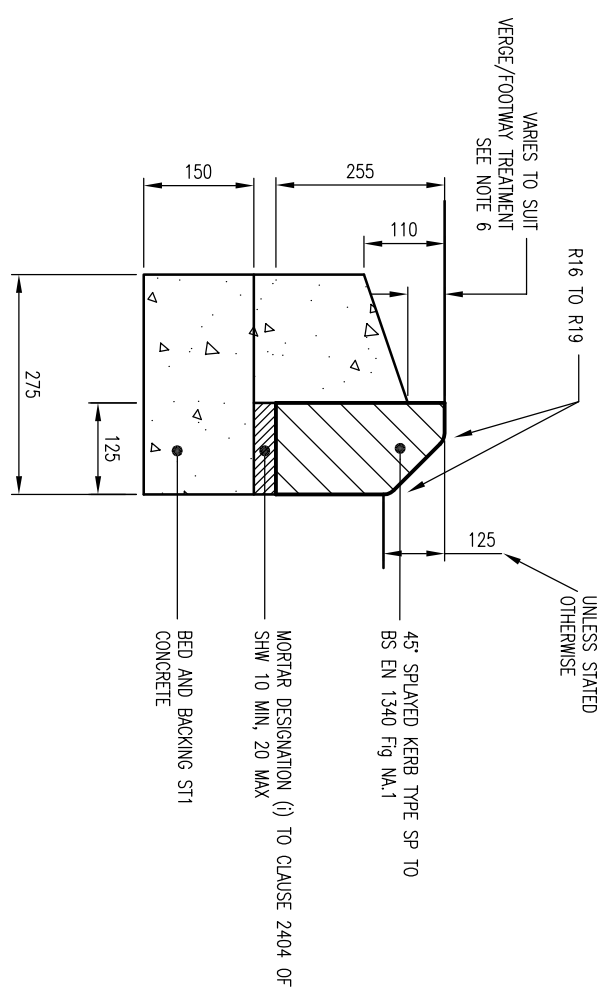

45° SPLOYED KERB TYPE SP

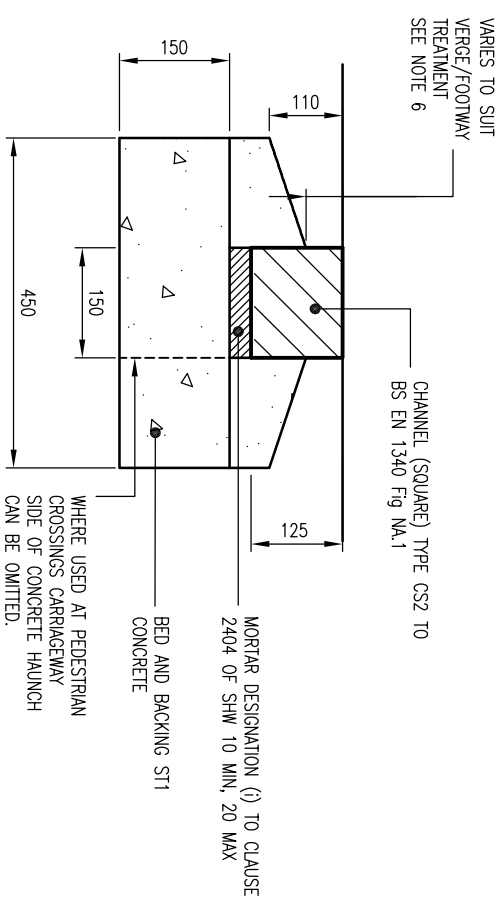

CHANNEL (SQUARE) TYPE CS2

DO NOT SCALE

- NOTES:
1. ALL DIMENSIONS ARE IN MILLIMETRES UNLESS OTHERWISE STATED.
 2. ALL CLAUSE NUMBERS REFER TO THE SPECIFICATION FOR HIGHWAY WORKS (SHW), LATEST EDITION.
 3. ALL PRECAST CONCRETE UNITS ARE TO CONFORM TO AND BE LAID IN ACCORDANCE WITH CL.1101 OF THE SPECIFICATION FOR HIGHWAY WORKS LATEST EDITION.
 4. KERB, BED AND BACKING SHALL BE ST1 GRADE CONCRETE TO CL.2602 OF THE SHW, LATEST EDITION.
 5. CONSERVATION KERB FACE (CK) TO BE 180mm HIGH UNLESS OTHERWISE INDICATED.
 6. TO BE 30mm WHEN ADJACENT TO THE GRASSED VERGE, AND 30mm PLUS THE DEPTH OF THE PAVING STONE WHEN ADJACENT TO PAVING STONES.
 7. MECHANICAL HANDLING OF HEAVY ITEMS IS RECOMMENDED
- TYPICAL WEIGHTS:
STANDARD PCC HB2 KERBS 69KG
CONSERVATION KERB 83KG
STANDARD PCC EDGING 45KG

| REV | DATE | BY | DESCRIPTION | CHK | APP |
|-----|----------|----|-------------------------------|-----|-----|
| C | 03/12/08 | JH | ISSUED FOR TECHNICAL APPROVAL | JAM | GH |
| B | 30/05/08 | JH | MINOR AMENDMENTS | LH | JM |
| A | 11/03/08 | JH | FIRST ISSUE | LH | JM |

FOR TECHNICAL APPROVAL



Mountbatten House, Basing View, Basingstoke, Hampshire RG21 4HJ
Tel: +44 (0)1256 318800 Fax: +44 (0)1256 318700
<http://www.wspgroup.com>

COUNTRYSIDE PROPERTIES

PROJECT:
SOUTH WEST BICESTER
BICESTER, OXFORDSHIRE

TITLE:
ON SITE WORKS
KERB TYPES SHEET 1 OF 2

| SCALE @ A3: | CHECKED: | APPROVED: |
|-------------|---------------|--------------|
| N.T.S | LH | JM |
| CAD FILE: | DESIGN/DRAWN: | DATE: |
| 1903-SD-210 | PJ | January 2008 |
| PROJECT No: | DRAWING No: | REV: |
| 11011903 | 1903/SD/210 | C |