

Our Ref: PJF/10387
(Please reply to Banbury office)

Will.Whitelock@framptons-planning.com

17th October 2023

Chris Wentworth
Principal Planner – Major Projects
Cherwell District Council
Development Management
Place & Growth Directorate
Bodicote House
Banbury
OX15 4AA

Dear Chris,

TOWN AND COUNTRY PLANNING ACT 1990

FULL PLANNING APPLICATION FOR DEMOLITION OF EXISTING RETAIL UNITS AND PUBLIC CAR PARK AND REDEVELOPMENT FOR RESIDENTIAL DWELLINGS (C3 USE), PROVISION OF PRIVATE CAR PARKING, HARD AND SOFT LANDSCAPING AND PHOTOVOLTAIC (PV) PANELS ON ROOF, AND ASSOCIATED WORKS (REF. 23/01633/F)

ON LAND BETWEEN CALTHORPE STREET AND MARLBOROUGH ROAD, BANBURY

I refer to the consultation response received from Active Travel England (ATE) on 7th August 2023 and write to address the comments raised.

ATE is not currently in a position to support this application and requests further assessment, evidence, revisions and/or dialogue as set out in the response.

For ease of reference, I have summarised each comment in turn below and provide commentary beneath each area of concern.

Banbury LCWIP - ATE recommend that the proposed development provides a financial contribution towards enhancing and delivering the amendments and enhancements to Route 1 proposed in the Banbury LCWIP (2022), considering the proximity to the application site and future usage by residents.

This comment aligns with the consultation response received from Oxfordshire County Council (OCC) Highways Authority (included at **Appendix 1**). Following discussions with the County Council, it is evident that the priority for cycling improvements in relation to proposed development are along Calthorpe Street. I attach a copy of the Letter of Response to Oxfordshire County Council prepared by the Highways Consultant (**Appendix 2**), which outlines proposals to provide a level surface crossing across Calthorpe Street by way of facilitating both safe and efficient pedestrian and cycle crossings, alongside cycle movements along Calthorpe Street as part of the Banbury LCWIP.

enquiries@framptons-planning.com
www.framptons-planning.com

Oriel House, 42 North Bar, Banbury,
Oxfordshire, OX16 0TH
T: 01295 672310 F: 01295 275606

Aylesford House, 72 Clarendon Street,
Leamington Spa, Warwickshire, CV32 4PE
T: 01926 831144

Such proposals were agreed in principle with OCC during a meeting held on 23rd August 2023, under the proviso that vehicular flows accord with LTN1/20 Table 4.1 – which has been confirmed by ATC survey evidence detailed within the aforementioned Letter (**Appendix 2**). These proposals would provide a connection between the proposed LCWIP Route 6 (Queensway > High Street) and Route 1 (A361).

Therefore, given the Applicant's agreement to provide to level surface crossing across Calthorpe Street which would facilitate pedestrian and cycle crossings and encourage cycle movements along Calthorpe Street, a financial contribution towards the enhancements to Route 1 of the Banbury LCWIP is not necessary to make the scheme acceptable in planning terms. Furthermore, given the number of cyclists likely to use the route, any contribution could not be justified as being proportionate in line with CIL 122.

Cycle Parking - Further detail would be welcomed on whether the proposed cycle parking on site is sufficient for larger bikes and e-bikes, including provision for charging (see LTN 1/20, figure 11.2). It is recommended that at least 5 per cent of all spaces accommodate non-standard bicycles.

The Highway Consultant's Letter of Response issued to OCC (**Appendix 2**) provides further detail of the proposed cycle parking provision (type and dimensions) and evidences the provision for both larger bikes and e-bikes. Furthermore, it is proposed to provide for bike hire lockers (Brompton Bike Hire) within the development, with some 16 spaces to be provided from the outset.

I trust this allays ATE's fears in relation to the proposed cycle parking provision.

Banbury Rail Station Cycle Infrastructure - There are currently 63 cycle spaces at Banbury Station, and considering this is likely to be cycled to by residents of the proposed development, a financial contribution towards infrastructure should be considered, such as increasing size and improving the infrastructure available at the station.

Section 4.5 of the submitted Transport Assessment sets out that Banbury railway station is accessible within 12-minutes on foot and approximately 8-minutes on bike. The safest and most direct route from the application site to Banbury railway station would be on foot walking through the town centre. As such, we consider that given the station's proximity, the majority of journeys to the station would be undertaken on foot, with cycling comprising a smaller proportion. Indeed, the submitted TA shows that the site is not as reliant on cycling in comparison to alternative sites beyond the Town Centre.

It is proposed to provide for bike hire lockers (Brompton Bike Hire) within the development, with some 16 spaces to be provided from the outset. These 'on demand' bikes are foldable and can therefore be taken on the train for onward travel, facilitating cycle movements at both ends of the journey – as is frequently required.

In light of the above considerations, it is not considered that this suggested financial contribution towards the enhancement of cycle parking facilities at Banbury Station is justified.

I trust you will concur with my planning analysis.

Yours sincerely,



Will Whitelock
Framptons

Appendix 1
Oxfordshire County Council - Highways Consultation Response

OXFORDSHIRE COUNTY COUNCIL'S RESPONSE TO CONSULTATION ON THE FOLLOWING DEVELOPMENT PROPOSAL

District: Cherwell

Application no: 23/01633/F

Proposal: Demolition of existing retail units and public car park and redevelopment for residential dwellings (C3 Use), provision of private car parking, hard and soft landscaping and photovoltaic (PV) panels on roof, and associated works.

Location: Site at Calthorpe Street and Marlborough Road, Banbury

Response Date: 20/07/2023

This report sets out the officer views of Oxfordshire County Council (OCC) on the above proposal. These are set out by individual service area/technical discipline and include details of any planning conditions or Informatives that should be attached in the event that permission is granted and any obligations to be secured by way of a S106 agreement. Where considered appropriate, an overarching strategic commentary is also included. If the local County Council member has provided comments on the application these are provided as a separate attachment.

Assessment Criteria

Proposal overview and mix /population generation

OCC's response is based on a development as set out in the table below. The development is taken from the application form.

Residential	
1-bed dwellings	154
2-bed dwellings	59
3-bed dwellings	9
4-bed & larger dwellings	8

Based on the completion and occupation of the development as stated above it is estimated that the proposal will generate the population stated below:

Average Population	388.68
Nursery children (number of 2- and 3-year olds entitled to funded places)	5.49
Primary pupils	22.97
Secondary pupils including Sixth Form pupils	17.56
Special School pupils	0.74
65+ year olds	44.83

Application no: 23/01633/F

Location: Site at Calthorpe Street and Marlborough Road, Banbury

General Information and Advice

Recommendations for approval contrary to OCC objection:

If within this response an OCC officer has raised an objection but the Local Planning Authority are still minded to recommend approval, OCC would be grateful for notification (via planningconsultations@oxfordshire.gov.uk) as to why material consideration outweighs OCC's objections, and to be given an opportunity to make further representations.

Outline applications and contributions

The anticipated number and type of dwellings and/or the floor space may be set by the developer at the time of application which is used to assess necessary mitigation. If not stated in the application, a policy compliant mix will be used. The number and type of dwellings used when assessing S106 planning obligations is set out on the first page of this response.

In the case of outline applications, once the unit mix/floor space is confirmed by reserved matters approval/discharge of condition a matrix (if appropriate) will be applied to establish any increase in contributions payable. A further increase in contributions may result if there is a reserved matters approval changing the unit mix/floor space.

Where a S106/Planning Obligation is required:

- **Index Linked** – in order to maintain the real value of S106 contributions, contributions will be index linked. Base values and the index to be applied are set out in the Schedules to this response.
- **Administration and Monitoring Fee - £6,350**
This is an estimate of the amount required to cover the monitoring and administration associated with the S106 agreement. The final amount will be based on the OCC's scale of fees and will be adjusted to take account of the number of obligations and the complexity of the S106 agreement.
- **OCC Legal Fees** The applicant will be required to pay OCC's legal fees in relation to legal agreements. Please note the fees apply whether a S106 agreement is completed or not.

Security of payment for deferred contributions - Applicants should be aware that an approved bond will be required to secure a payment where a S106 contribution is to be paid post implementation and

- the contribution amounts to 25% or more (including anticipated indexation) of the cost of the project it is towards and that project cost £7.5m or more

- the developer is direct delivering an item of infrastructure costing £7.5m or more
- where aggregate contributions towards bus services exceeds £1m (including anticipated indexation).

A bond will also be required where a developer is direct delivering an item of infrastructure.

The County Infrastructure Funding Team can provide the full policy and advice, on request.

Application no: 23/01633/F

Location: Site at Calthorpe Street and Marlborough Road, Banbury

Transport Schedule

Recommendation:

Objection for the following reasons:

- Whilst the development is located in a sustainable location, it lacks safe cycle access. Without mitigation this is contrary to LTCP Policy 2b, Local Plan Policy SLE4, and NPPF Paragraph 110.
- The proposed cycle parking does not meet OCC Parking Standards

If despite OCC's objection permission is proposed to be granted then OCC requires prior to the issuing of planning permission a S106 agreement including an obligation to enter into a S278 agreement to mitigate the impact of the development plus planning conditions and informatives as detailed below.

S106 Contributions

Contribution	Amount £	Price base	Index	Towards (details)
Cycle and pedestrian infrastructure	TBC			New and upgraded facilities as part of the Banbury LCWIP and improvements to pedestrian infrastructure in the town centre.
Public transport infrastructure (<i>if not dealt with under S278/S38 agreement</i>)	£9,356	Oct 2021	Baxter	Bus stop real time information display
Traffic Reg Order (<i>if not dealt with under S278/S38 agreement</i>)	£3,652	April 2023	RPI-x	Costs related to advertising and consulting on changes to parking restrictions in the vicinity
Travel Plan Monitoring	£1558	Dec 2021	RPI-x	Cost to OCC of monitoring the travel plan.

Total				

Other obligations:

- Off-site highway works – site access junctions, improvements to footways on Marlborough Rd and Calthorpe Street, crossing of Calthorpe Street

Key points

- Site is in a sustainable town centre location
- However, improvements needed to pedestrian and cycle access and linkages
- Contribution also required for bus real time information
- Clarification required on connectivity across the site
- Cycle parking is not sufficient in line with Oxfordshire Parking Standards
- Clarification required on location and detail of cycle parking
- Some car free development is supported, but clarification required on whether parking is allocated. Alterations to nearby TRO/Residents parking may be required to address potential overspill parking.
- Information required on how construction would be managed so as to minimise impact on users of the highway
- Concern about loss of trees and impact on pedestrian environment

Comments:

Introduction

This application is for a high density residential development of 230 dwellings on land currently occupied by large retail stores and a public car park. The majority of the development comprises 1 and 2-bedroom flats, with only 9 houses. To address the level change across the site, there would be significant earthworks to create a lower ground level, including undercroft parking, and a ground level.

Loss of a foodstore from the town centre is regrettable in terms of walkable neighbourhoods, but there are other foodstores in the vicinity. If any of the stores were to locate to an out of town location, this would be less sustainable in transport terms, but that would need to be balanced with the positive impact of locating dwellings close to public transport hubs, employment and local facilities.

Access arrangements

A primary vehicular access would be created off Marlborough Road in approximately the position of the current car park access. This would provide pedestrian and cycle access, access to only a few car parking spaces, and a service access. Due to the level changes described above, this would not be steeply ramped as at present.

The northern apartment block would have pedestrian access directly into its ground level units from Marlborough Street and Calthorpe Street. A new pedestrian access would be created onto Calthorpe Street north of the existing Calthorpe House.

In approximately the location of the Calthorpe Street entrance to the NCP car park, a vehicle access via a ramp down into the undercroft car park, and a separate pedestrian access into the site would be provided. In approximately the position of the service access to the TKMaxx/Farmfoods stores, a vehicle and pedestrian access would be provided – this would provide vehicle access to the townhouses only. The existing small carpark at the southern end of the site on Calthorpe Road would remain.

The vehicular access positions are acceptable in principle and the works required to create/adapt them will require a S278 agreement with OCC. However, they will need to be designed to create continuous level footways with pedestrian priority across the accesses. **Details of off-site highway works to be provided.**

It is assumed that the access roads within the site would not be offered for adoption but this should be clarified. Adoption may affect the choice of materials and landscaping that can be provided. **Clarification required.**

Pedestrian and cycle connectivity

The permeability of the site is welcomed and necessary to encourage walking and cycling. However, it isn't clear whether the southern access onto Calthorpe Road is stepped. It's assumed the access route between Marlborough Road and the northern access onto Calthorpe Road is step-free but this needs to be clarified. Please provide further clarification of where the steps are. It is stated that there is to be a lift to take people between the landscaped levels in the main north south route through the site. A ramp would be much preferable, as lifts like this are very frequently found out of order. **Further information required.**

There should be level or ramped routes for bins and trolleys for deliveries to residents, which do not rely on this external lift. **More information is required to demonstrate these routes.**

The access points onto Calthorpe Road should be accessible for cycles, and at least one should allow for cycles to be ridden, and should therefore be 3 metres wide. Both accesses currently look too narrow.

Although the site is located within easy cycling distance of employment and facilities, cycling connectivity across the town centre is currently poor. I am not sure whether the cycling times shown in the transport assessment take account of this. It is not possible for cyclists to turn right onto Marlborough Road. They can turn left and then right onto the high street but would then need to turn right into George Street, i.e. they are not permitted in the pedestrianised part of High Street. To access employment to the north of the town they would need to use South Bar and North Bar.

The Transport Assessment states at 4.3.2 that the 'local roads are of suitable geometry and sufficiently low vehicular speeds that informal cycling in the carriageway is possible without detriment to highway safety'. While it is expected that the surrounding roads will, subject to consultation, be subject to a 20mph speed limit in the next year or so, even at this speed, traffic volumes are almost certainly above the volumes set out in LTN 1/20 which set a threshold for requiring dedicated space for cycling.

The Oxfordshire LTCP Policy 2b states that 'We will ensure that all new developments have safe and attractive walking and cycling connections to the site..'
According to the LTN 1/20, infrastructure would be required as mitigation for the site, to provide a safe connection for cyclists.

The Local Cycling and Walking Infrastructure Plan for Banbury is expected to be approved later this week, and sets out key routes in Banbury requiring upgrade. Route 1 goes north-south along South Bar and North Bar and would be used by residents at the site to access employment sites to the north. Route 2 connects South Bar to Bloxham Road via Crouch Street and would be used as a connecting route to schools. An onward connection along Calthorpe Street would connect this route to the town centre.

In terms of walking, conditions for pedestrians in Calthorpe St and Marlborough Road are poor, and the developer should provide improvements along the frontages of the development as part of S278 works, including continuous footways across the accesses. Dropped kerbs will be required at the pedestrian access points, for pushing (but preferably riding) cycles. A crossing on Calthorpe Street should be provided, which could be in combination with a raised table junction incorporating access to the council car park. The bus stop on Calthorpe Road should be incorporated into the design, potentially with additional seating, and the shelter should be shown on the drawings and elevations.

A package of decluttering and localised pedestrian improvements to the route between the site and town centre, via the High Street, is being developed as an action of the LCWIP. The site is required to make a financial contribution to provide for OCC to deliver this, in addition to the crossing upgrade on South Bar, which is a key cycle link, and cycle facilities on Calthorpe Street to link to it.

I am concerned about the loss of a number of mature trees on Calthorpe Street and Marlborough Road. It looks as though these are not highway trees (though this should be confirmed by a detailed survey of the highway boundary). These provide shade and other benefits and their loss will lead to a deterioration in the environment, making walking less

attractive. The loss of these trees contributes to the requirement for the site to provide for off-site mitigating measures to improve conditions for pedestrians (and local residents).

Public transport

We are satisfied there is good provision of bus services in the vicinity of the development. We therefore don't require a bus service contribution in this instance – this also reflects the location of the development being in the town centre and therefore a short walking distance to a number of services and employment opportunities.

Note the table of buses serving the Calthorpe Street stop is incomplete, route S4 (linking Banbury with Oxford) also stops here and is probably the most significant of any of the routes from this stop.

The closest bus stop to the development, the Calthorpe Street stop, is already equipped with a fairly new bus shelter. It does not however have real-time information. To provide an attractive, up to date travel experience that people will have confidence in using, a real-time information screen is required in the shelter. **A contribution is therefore required for £9,356 for this provision of real-time information in the vicinity of the site** (Baxter indexed, base October 2021).

Car parking

Within the site, only the existing small car park at the southern end of Calthorpe Road would remain as public car parking. The transport assessment contains an assessment of the impact of the loss of public parking spaces that would result from the development, taking into account that a proportion of the demand for parking at the current NCP car park at the site would be generated by the existing retail, which would be lost as a result of the development. Parking surveys were carried out in March 2023 showing 22% residual parking capacity within the town centre. It concludes that there is sufficient capacity in other car parks within a 400m radius to accommodate all demand.

The parking provided for residents is limited, though the parking provision needs to be clarified. The TA states that there would be 63 unallocated spaces in the undercroft parking area (in addition to the 9 allocated outside the townhouses), but the Design and Access statement (chapter 7) states that it is anticipated that spaces will be allocated to units, to reduce unexpected demand for parking in the vicinity of the site and the likelihood of residents driving around looking for spaces. If spaces are allocated, they must all have an EV charging point (parking standards para 4.11). If not allocated, then in addition to those with a live charging point, all spaces must have ducting for future charging points.

The concept of car free development is supported by OCC's parking standards (para 4.12) where the site is within a town with parking restrictions imposed within its vicinity, has good sustainable transport access and is within 800m of local amenities and services, all of which apply here. However, it also says that OCC will require such sites to incorporate a Controlled Parking Zone into a site's master plan where a CPZ does not already exist. If

parking is unallocated, residents finding themselves unable to park in the development may take up time restricted bays in the area and/or park inappropriately in the local area overnight. **Further information required.**

There may be some requirement to amend the restrictions on some nearby bays and introduce loading bans, or even resident permit bays for existing residents. The Travel Plan suggests that the LHA could preclude the granting of parking permits for those apartments which do not benefit from allocated spaces. However the development is not currently within a Residents' Parking Zone. The direct frontages on Marlborough and Calthorpe Road may result in a need for a loading restriction.

A contribution will be required for OCC to consult on and make necessary changes to parking TROs in the area.

Cycle parking

A number of cycle stores are provided throughout the site, although their location is not clear from the floor plans, on which they are not labelled. Further detail is required to understand exactly where these stores are, how they are accessed, and the type of cycle parking within them. The OCC Parking Standards state that cycle parking should be provided in a convenient location close to building entrances and that the parking should be in the style of a Sheffield stand, not double-decked or vertical unless agreed by OCC in special circumstances. **Further information required.**

The TA states that cycle parking would be provided at one space for a 1-bedroom unit, and 2 spaces for larger units. However, since our preapplication advice the parking standards have been updated. The requirement is now for 2 spaces per bedroom. **Reason for objection.**

Covered cycle parking for the townhouses is absent from the plans and should be included **Reason for objection**

Each cycle parking store should provide for e-bike charging.

Cycle parking should not be left to condition, as it needs to be established that it can be accommodated to the right standard within the layout.

Refuse collection

Refuse collection would be from within the development, however bin stores are not labelled on the floor plans. **Further information required.**

Traffic impact

The TA compares the peak hour and daily trip generation of the proposed development with the extant land uses on the site, and this results in a significant reduction in vehicle

movements. Therefore the traffic impact of the development cannot be considered to be severe.

Travel Plan

The Applicant has submitted a framework travel plan with this outline application, this plan is fine for this stage of the application however it will need to be updated to a full travel plan prior to the first occupation of this site. Details of the information required in the full travel plan can be obtained from the Oxfordshire County Council guidance document; Transport for new developments, Transport Assessments and Travel Plans (March 2014).

This updated travel plan will need to provide baseline travel information, modal shift targets, a detailed action plan with a timeline and responsible person and budget for the delivery of these targets.

As part of the travel plan actions the developer should provide the new residents with Travel Information packs to support them in active travel choices.

Construction

Because of the amount of earthworks there is potential for a high volume of HGV movements in a residential area. Further details are required of how the construction impact would be managed, which accesses would be used etc. Calthorpe Road access would be preferable. All deliveries must take place within the site. **Further information required.**

On Marlborough Road the development appears to abut the back of the footway. There must be no overhanging of any part of the buildings over the highway, including windows. Any requirement for closure of footways would require a safe alternative route to be provided.

Surface water from the development must not drain onto the highway.

S106 obligations and their compliance with Regulation 122(2) Community Infrastructure Levy Regulations 2010 (as amended):

£TBC Cycle and Pedestrian Infrastructure Contribution indexed from XX using Baxter Index

Towards: Cycle infrastructure on Calthorpe Street, upgrade of crossing on South Bar connecting into LCWIP route, and localised pedestrian improvements in High Street.

Justification: Roads leading to the site do not have dedicated cycle infrastructure segregating cyclists from traffic, which is required to provide safe cycle access to the development. Conditions for pedestrians are poor and improvements are required to encourage walking to/from the site. LTCP Policy 2b, Local Plan Policy SLE4, NPPF Para 110.

Calculation: TBC

£9,356 Public Transport Infrastructure Contribution indexed from Oct 2021 using Baxter Index

Towards: Bus stop real time information display.

Justification: Required to encourage bus travel to/from the site. LTCP Policy 18e, NPPF Para 110

Calculation: This is the standard cost to OCC of providing and maintaining the unit.

£3,652 Traffic Regulation Order Contribution indexed from April 2023 using RPI-x

Towards: Cost to OCC of advertising and consulting on changes to parking restrictions in the area.

Justification: Car free development may lead to residents' parking overnight in timed bays nearby, reducing space available for existing residents and potentially causing unsafe parking on junctions, obstructing footways etc.

Calculation: This is a standard cost set out in the council's list of fees and charges.

£1,558 Travel Plan Monitoring Fee indexed from Dec 2021 using RPI-x

Justification: A travel plan is required to ensure uptake of sustainable travel to/from the site. The travel plan needs to be a live document, with surveys carried out and regular monitoring and review of measures. The contribution is required to cover the cost to OCC of monitoring the travel plan, without which it would be ineffective.

Calculation: The amount is standard for this size of development, and has been calculated based on an estimate of officer time required to review the travel plan over five years.

S278 Highway Works:

- An obligation to enter into a S278 Agreement will be required to secure mitigation/improvement works, including site access junctions, continuous footway along Calthorpe Street and Marlborough Road frontages, and crossing of Calthorpe Street.

Notes:

This is to be secured by means of S106 restriction not to implement development (or occasionally other trigger point) until S278 agreement has been entered into.

The trigger by which time S278 works are to be completed shall also be included in the S106 agreement.

Identification of areas required to be dedicated as public highway and agreement of all relevant landowners will be necessary in order to enter into the S278 agreements.

Planning Conditions:

In the event that permission is to be given, the following planning conditions should be attached:

No development shall commence unless and until full details of the means of vehicle, pedestrian and cycle access between the land and the highway, together with footway and crossing improvements on the site frontages, including, position, layout, construction, drainage and vision splays have been submitted to and approved in writing by the Local Planning Authority. The means of access shall be constructed in strict accordance with the approved details and shall be retained and maintained as such thereafter. Agreed vision splays shall be kept clear of obstructions higher than 0.6m at all times.

Reason - In the interests of highway safety and to comply with Policy ESD15 of the Cherwell Local Plan 2011-2031 Part 1 and Government guidance contained within the National Planning Policy Framework.

No development shall commence unless and until full specification details (including construction, layout, surfacing and drainage) of the turning area and parking spaces within the curtilage of the site, arranged so that motor vehicles may enter, turn round and leave in a forward direction and vehicles may park off the highway, have been submitted to and approved in writing by the Local Planning Authority. The turning area and car parking spaces shall be constructed in accordance with the approved details prior to the first occupation of the development shall be retained as such for the parking and manoeuvring of vehicles at all times thereafter.

Reason - In the interests of highway safety and to comply with Policy ESD15 of the Cherwell Local Plan 2011-2031 Part 1 and Government guidance contained within the National Planning Policy Framework.

Prior to the first use or occupation of the development hereby permitted, covered cycle parking facilities shall be provided on the site in accordance with details which shall be firstly submitted to and approved in writing by the Local Planning Authority. Thereafter, the covered cycle parking facilities shall be permanently retained and maintained for the parking of cycles in connection with the development.

Reason - In the interests of sustainability, to ensure a satisfactory form of development and to comply with Government guidance contained within the National Planning Policy Framework.

Prior to the first occupation of the development, a scheme for the provision of vehicular electric charging points to serve the development shall be submitted to and approved in

writing by the Local Planning Authority. The vehicular electric charging points shall be provided in accordance with the approved details prior to the first occupation of the unit they serve, and retained as such thereafter.

Reason - To comply with Policies SLE 4, ESD 1, ESD 3 and ESD 5 of the adopted Cherwell Local Plan 2011-2031 Part 1 and to maximise opportunities for sustainable transport modes in accordance with paragraph 110(e) of the National Planning Policy Framework

Prior to commencement of the development hereby approved, a Construction Traffic Management Plan (CTMP) shall be submitted to and approved in writing by the Local Planning Authority. Thereafter, the development shall not be carried out other than in accordance with the approved CTMP.

Reason: In the interests of highway safety and the residential amenities of neighbouring occupiers and to comply with Government guidance contained within the National Planning Policy Framework.

Prior to the first occupation of the development hereby approved, a Travel Plan, prepared in accordance with the Department of Transport's Best Practice Guidance Note "Using the Planning Process to Secure Travel Plans", shall be submitted to and approved in writing by the Local Planning Authority. Thereafter, the development shall be implemented and operated in accordance with the approved details.

Reason - In the interests of sustainability and to ensure a satisfactory form of development, in accordance with Government guidance contained within the National Planning Policy Framework.

Prior to commencement of the development hereby approved, a Parking Management Plan shall be submitted to and approved in writing by the Local Planning Authority. Thereafter, the development shall not be carried out other than in accordance with the approved Parking Management Plan.

Reason - In light of the reduced amount of on-site parking, to mitigate the risk of residents' parking overspilling into the local area and causing a nuisance and/or a danger to road users.

Informatives:

Prior to the commencement of a development, a separate agreement(s) must be obtained from Oxfordshire County Council's (OCC) Road Agreements Team for the proposed highway works (vehicular access, new footway links, bus infrastructure, pedestrian refuge island, carriageway widening and new right-turn lane) under S278 of the Highways Act 1980. For guidance and information please contact the county's Road Agreements Team via <https://www.oxfordshire.gov.uk/cms/content/contact-road-agreements-team>.

It is an offence under S151 of the Highways Act 1980 for vehicles leaving the development site to carry mud onto the public highway. Facilities should therefore be provided and used on the development site for cleaning the wheels of vehicles before they leave the site.

No vehicles associated with the building operations on the development site shall be parked on the public highway, so as to cause an obstruction. Any such obstruction is an offence under S137 of the Highways Act 1980.

Officer's Name: Joy White

Officer's Title: Principal Transport Planner

Date: 19/07/2023

Appendix 2
Highways consultant response to OCC Highways

Our reference 22-312-20

Date 13th October 2023

Joy White
Principal Transport Planner
Transport Development Control
Oxfordshire County Council
County Hall
New Road
Oxford
OX1 1ND

BY EMAIL ONLY

Dear Joy,

RE: CALTHORPE STREET, BANBURY – LETTER OF RESPONSE

I am writing further to your Authority's comments dated 19th July 2023 in respect of planning application 23/01633/F, which seeks permission for the redevelopment of retail units & public car park into residential dwellings.

Within your Authority's response, a number of queries are raised which have encouraged minor modifications to the plans, alongside the provision of additional information by way of clarification. Consequently, this letter has been prepared to provide a response against each of the matters raised in your comments, based on the most up to date plans submitted, which we are confident will enable you to provide a positive consultation response on behalf of your Authority.

For ease, we set out each of your comments and our response individually, below.

Cycle Parking

Comment 1

"A number of cycle stores are provided throughout the site, although their location is not clear from the floor plans, on which they are not labelled. Further detail is required to understand exactly where these stores are, how they are accessed, and the type of cycle parking within them. The OCC Parking Standards state that cycle parking should be provided in a convenient location close to building entrances and that the parking should be in the style of a Sheffield stand, not double-decked or vertical unless agreed by OCC in special circumstances."

"Each cycle parking store should provide for e-bike charging."

Following the comments, we have sought to produce plans to clarify the position of cycle stores across the site. With this, Section 1.4 of the appended Corstorphine & Wright Accessibility Report details all proposed locations – with cycle stores conveniently located; close to the building entrances and being directly accessible from outside.

With regards to the design of the cycle parking, the proposals have been amended to provide a mixture of horizontal and semi-vertical racks (91 horizontal and 197 semi-vertical racks), both types of parking available to each residential block. The semi-vertical racks can be provided with electric charging points and as such, each block will be afforded access to electric bike charging spaces.

We trust that the above information and agreement future Travel Plan surveys to gauge demand address Comment 1 in full.

Comment 2

“The TA states that cycle parking would be provided at one space for a 1-bedroom unit, and 2 spaces for larger units. However, since our preapplication advice the parking standards have been updated. The requirement is now for 2 spaces per bedroom.”

In response, we note that the provision included within the submitted Transport Assessment exceeds the quantum suggested by OCC in the previous pre-application response (Ref: 22/00492/PREAPP), and that during the design process OCC released the updated requirements outlined above. As such, we have a development that responds to the pre-application documentation within a highly sustainable location for which all travel options should be considered. In this way, given the site's proximity to the town centre; with a considerable number of amenities, jobs, and public transport stops accessible within a very short walk, it is considered that the site is not reliant on bicycle trips in the way that development further outside of the town centre may be. Therefore, it is highly unlikely given the mix of travel options that there will be more than two people per unit needing to use a bike to travel to their destinations. Consequently, it is considered that further bicycle parking could represent a significant overprovision relative to the demand.

A better of way dealing with this would be to provide a form of on demand cycle provision, such as, a Brompton bike hire vending machine. This would avoid the need to provide cycle parking for the infrequent and mostly leisure-based trip purposes. This was discussed at the meeting with OCC (dated 23rd August 2023), where there was broad agreement. This has now been discussed with the applicant, with agreement to provide the Brompton machine in the centralised and highly visible location shown within Section 1.5 of the appended Accessibility Report.

As suggested by OCC, the Travel Plan Coordinator will monitor demand via Brompton's usage statistics – which are recorded at each locker location. As such, the requirement for further spaces can be determined. Alongside this, OCC requested that we identify the potential locations for an additional locker within the site. In this way, Section 1.5 (page 12) of the appended report outlines an additional location within the centre of the site.

We trust that the above information and agreement future Travel Plan surveys to gauge demand address Comment 2 in full.

Comment 3

“Covered cycle parking for the townhouses is absent from the plans and should be included.”

We have sought to provide clarity on the location and type of provision in line with comments. With this, Section 1.4 (page 9) of the appended Accessibility Report outlines that cycle parking for the townhouses will be provided as covered, secured parking within the rear gardens. Each property will be able to access the rear garden separately from the house.

Pedestrian & Cycle Accessibility

Comment 4

The permeability of the site is welcomed and necessary to encourage walking and cycling. However, it isn't clear whether the southern access onto Calthorpe Road is stepped. It's assumed the access route between Marlborough Road and the northern access onto Calthorpe Road is step-free, but this needs to be clarified. Please provide further clarification of where the steps are. It is stated that there is to be a lift to take people between the landscaped levels in the main north south route through the site. A ramp would be much preferable, as lifts like this are very frequently found out of order.

The access points onto Calthorpe Road should be accessible for cycles, and at least one should allow for cycles to be ridden and should therefore be 3 metres wide. Both accesses currently look too narrow.

We welcome OCC's comments on the permeable nature of the proposed design. In consideration of the location non-car access, Corstorphine & Wright have produced an 'LA Highways Comments – Accessibility Report' – enclosed herewith. Section 1.1 (page 4) details five pedestrian / cycle access points proposed across the site – with Point 1 (Smithy Walk, Marlborough Road) and Point 3 (Manor Gardens) provide both pedestrian and cycle access by way of a shared surface access. With this, the shared surfaces measure at least 6-metres in width and afford access to a limited number of parking spaces and therefore vehicular movements (3 spaces from Point 1 and 9 parking spaces from Point 3). As such, both Calthorpe Street and Marlborough Road provide safe and efficient accesses for bicycles.

To provide further clarity, the southern access from Calthorpe Street is provided as a shared surface ramped access up to blocks A, C, and the town houses. Movement south>north from this access is provided by either steps or a platform lift. As per the appended report, it is considered that the continuous operation of the lift can be guaranteed via a suitably worded condition.

Comment 5

Although the site is located within easy cycling distance of employment and facilities, cycling connectivity across the town centre is currently poor. I am not sure whether the cycling times shown in the transport assessment take account of this. It is not possible for cyclists to turn right onto Marlborough Road. They can turn left and then right onto the high street but would then need to turn right into George Street, i.e., they are not permitted in the pedestrianised part of High Street. To access employment to the north of the town they would need to use South Bar and North Bar.

It is welcome that OCC recognise the site's accessibility to employment facilities within Banbury. To provide confirmation to the Local Highway Authority, the accessibility catchments contained within the submitted Transport Assessment allow for cyclists to dismount and walk with their bikes through the pedestrianised environment – with this the links in question have a modified cycle speed of 4.8kmh – in line with typical walk speeds. Therefore, the accessibility catchment plans submitted are an accurate reflection of the areas accessible by bicycle.

Comment 6

“The Transport Assessment states at 4.3.2 that the ‘local roads are of suitable geometry and sufficiently low vehicular speeds that informal cycling in the carriageway is possible without detriment to highway safety’. While it is expected that the surrounding roads will, subject to consultation, be subject to a 20mph speed limit in the next year or so, even at this speed, traffic volumes are almost certainly above the volumes set out in LTN 1/20 which set a threshold for requiring dedicated space for cycling.

The Oxfordshire LTCP Policy 2b states that ‘We will ensure that all new developments have safe and attractive walking and cycling connections to the site.’ According to the LTN 1/20, infrastructure would be required as mitigation for the site, to provide a safe connection for cyclists.

The Local Cycling and Walking Infrastructure Plan for Banbury is expected to be approved later this week and sets out key routes in Banbury requiring upgrade. Route 1 goes north south along South Bar and North Bar and would be used by residents at the site to access employment sites to the north. Route 2 connects South Bar to Bloxham Road via Crouch Street and would be used as a connecting route to schools. An onward connection along Calthorpe Street would connect this route to the town centre.”

A crossing on Calthorpe Street should be provided, which could be in combination with a raised table junction incorporating access to the council car park. The bus stop on Calthorpe Road should be incorporated into the design, potentially with additional seating, and the shelter should be shown on the drawings and elevations.

A package of decluttering and localised pedestrian improvements to the route between the site and town centre, via the High Street, is being developed as an action of the LCWIP. The site is required to make a financial contribution to provide for OCC to deliver this, in addition to the crossing upgrade on South Bar, which is a key cycle link, and cycle facilities on Calthorpe Street to link to it.

In response to the above, LTN1/20 documentation outlines the recommended protections / cycle provision at varying speed and volumes, as per paragraph 7.1.1 below: -

“Where motor traffic flows are light and speeds are low, cyclists are likely to be able to cycle on-carriageway in mixed traffic, as shown in Figure 4.1. Most people, especially with younger children, will not feel comfortable on-carriageways with more than 2,500 vehicles per day and speeds of more than 20 mph. These values should be regarded as desirable upper limits for inclusive cycling within the carriageway.”

For context, Figure 4.1 of the LTN1/20 document is provided below.

Figure 1 – Appropriate protection from motor traffic on highways – LTN1/20

Speed Limit ¹	Motor Traffic Flow (pcu/24 hour) ²	Protected Space for Cycling			Cycle Lane (mandatory/ advisory)	Mixed Traffic
		Fully Kerbed Cycle Track	Stepped Cycle Track	Light Segregation		
20 mph ³	0	Green	Green	Green	Green	Green
	2000	Green	Green	Green	Green	Green
	4000	Green	Green	Green	Yellow	Yellow
	6000+	Green	Green	Green	Yellow	Yellow
30 mph	0	Green	Green	Green	Yellow	Yellow
	2000	Green	Green	Green	Yellow	Yellow
	4000	Green	Green	Green	Yellow	Yellow
	6000+	Green	Green	Green	Yellow	Yellow
40 mph	Any	Green	Yellow	Yellow	Pink	Pink
50+ mph	Any	Green	Pink	Pink	Pink	Pink

■ Provision suitable for most people

■ Provision not suitable for all people and will exclude some potential users and/or have safety concerns

■ Provision suitable for few people and will exclude most potential users and/or have safety concerns

Notes:

1. If the 85th percentile speed is more than 10% above the speed limit the next highest speed limit should be applied
2. The recommended provision assumes that the peak hour motor traffic flow is no more than 10% of the 24 hour flow
3. In rural areas achieving speeds of 20mph may be difficult, and so shared routes with speeds of up to 30mph will be generally acceptable with motor vehicle flows of up to 1,000 pcu per day

In line with this we have assessed the volume of traffic using Calthorpe Street via the ATC surveys undertaken as part of the submitted Transport Assessment – Appendix C. For context, ATC surveys were undertaken between the dates of 22nd – 28th March 2023 at locations shown within the appended information. From the ATC data provided, the traffic volume for Calthorpe Street has been converted to PCUs within the Table below.

Table 1 - Traffic Volume in PCUs per ATC Site

		Car / LGV	OGV1 / Bus	OGV2	TOTAL PCU
ATC 1	NB	1,401	38	3	1,442
	SB	937	73	1	1,011
	Two-Way	2,338	111	5	2,453
ATC 2	SB	1317	52	4	1,373
	NB	939	98	8	1,045
	Two-Way	2,256	150	12	2,418

*PCU conversion from traffic counts: - car = 1, OVG1 = 2, Bus = 2, OGV2 = 2.3

Further to the above, the submitted ATC surveys evidence that peak hour volumes are at 9.5 and 9.3 percent, respectively, of the total 24-hour flows and are therefore below the recommended 10% as per LTN1/20 guidance.

From the above analysis, it is evident that Calthorpe Street affords sufficiently low volumes to accommodate cyclists within the carriageway as mixed traffic without detriment to safety. Therefore, Calthorpe Street does not require a cycle lane or specific cycle infrastructure, in line with LTN1/20 guidance.

Further, it should be considered that the submitted Transport Assessment has evidenced that a material number of the identified vehicles above are travelling along Calthorpe Street to access the current land-uses on the site along with commuters using the existing NCP car park. Indeed, Section 10.3 the submitted Transport Assessment evidences that proposed development is anticipated to see a change in vehicular traffic of circa -847 two-way trips per day.

With regard to vehicular speed, we acknowledge that the ATC results contained at [Appendix C](#) of the submitted Transport Assessment evidence 85th percentile speeds of 24mph – exceeding the 10% threshold by some 2mph. However, in line with discussions with OCC as per 23rd August 2023 and per the comment above we note that the forthcoming LCWIP will limit vehicular speeds to 20mph along Calthorpe Street and other street across the Town Centre.

On the basis of the above, a raised table crossing is proposed as a way of traffic calming such that the average speed will be in adherence to the 20mph limit. And in so doing, in reference to the traffic flows there will be no need for further cycling improvements. The proposed crossing facility has been shown in the figure below, whilst provided to scale at Appendix X.

[INSERT CROSSING PLAN]

We trust that the above information and agreement of a level surface crossing across Calthorpe Street address Comment 6 in full.

Comment 7

***“In terms of walking, conditions for pedestrians in Calthorpe St and Marlborough Road are poor, and the developer should provide improvements along the frontages of the development as part of S278 works, including continuous footways across the accesses. Dropped kerbs will be required at the pedestrian access points, for pushing (but preferably riding) cycles*”**

The existing footway network is already used to accommodate pedestrian movements associated with the extant uses and our own observations suggest that the geometry of the footway are acceptable. However, as part of the proposals, footways will be reinstated and localised resurfacing will be provided as part of these works.

Access Arrangements

Comment 8

***“The vehicular access positions are acceptable in principle and the works required to create/adapt them will require a S278 agreement with OCC. However, they will need to be designed to create continuous level footways with pedestrian priority across the accesses.”*”**

We can confirm that detailed design through Section 278 will be undertaken to create continuous footways across the site accesses to afford priority for pedestrians.

Comment 9

***“It is assumed that the access roads within the site would not be offered for adoption, but this should be clarified. Adoption may affect the choice of materials and landscaping that can be provided.”*”**

We can confirm that the access roads within the site will not be offered for adoption but rather their maintenance will be incorporated as a responsibility of the management company.

Car Parking

Comment 10

“The parking provided for residents is limited, though the parking provision needs to be clarified. The TA states that there would be 63 unallocated spaces in the undercroft parking area (in addition to the 9 allocated outside the townhouses), but the Design and Access statement (chapter 7) states that it is anticipated that spaces will be allocated to units, to reduce unexpected demand for parking in the vicinity of the site and the likelihood of residents driving around looking for spaces. If spaces are allocated, they must all have an EV charging point (parking standards para 4.11). If not allocated, then in addition to those with a live charging point, all spaces must have ducting for future charging points.”

We can confirm that all spaces will be provided as allocated spaces. In line with the above, all spaces will be provided with an EV charging point.

Comment 11

“The concept of car free development is supported by OCC’s parking standards (para 4.12) where the site is within a town with parking restrictions imposed within its vicinity, has good sustainable transport access and is within 800m of local amenities and services, all of which apply here. However, it also says that OCC will require such sites to incorporate a Controlled Parking Zone into a site’s master plan where a CPZ does not already exist. If parking is unallocated, residents finding themselves unable to park in the development may take up time restricted bays in the area and/or park inappropriately in the local area overnight. Further information required. There may be some requirement to amend the restrictions on some nearby bays and introduce loading bans, or even resident permit bays for existing residents. The Travel Plan suggests that the LHA could preclude the granting of parking permits for those apartments which do not benefit from allocated spaces. However, the development is not currently within a Residents’ Parking Zone. The direct frontages on Marlborough and Calthorpe Road may result in a need for a loading restriction. A contribution will be required for OCC to consult on and make necessary changes to parking TROs in the area.”

The applicant is willing to make a financial contribution of £3,652 in line with OCC’s response – dated 19/07/23.

Refuse Collection & Delivery Access

Comment 12

Refuse collection would be from within the development, however bin stores are not labelled on the floor plans.

There should be level or ramped routes for bins and trolleys for deliveries to residents, which do not rely on this external lift.

We have sought to clarify both the refuse and delivery stores and routes in response to the above comments from OCC. With this Corstorphine & Wright have included detailed plans showing refuse and delivery accessibility routes to the respective stores and building entrances across the site within the appended report. For confirmation, all refuse stores and main entrances for deliveries can be accessed step free and do not require use of the external lift proposed within the site.

Public Transport

Comment 13

"The closest bus stop to the development, the Calthorpe Street stop, is already equipped with a fairly new bus shelter. It does not however have real-time information. To provide an attractive, up to date travel experience that people will have confidence in using, a real-time information screen is required in the shelter. A contribution is therefore required for £9,356 for this provision of real-time information in the vicinity of the site."

We confirm that the stated amount of £9,356 would be acceptable and secured under S106 agreement.

Construction

Comment 14

"Because of the amount of earthworks there is potential for a high volume of HGV movements in a residential area. Further details are required of how the construction impact would be managed, which accesses would be used etc. Calthorpe Road access would be preferable. All deliveries must take place within the site."

We can confirm that a CTMP will be provided at future date, and this can be secured by an appropriately worded condition.

Closure

I trust the above clarifications suitably respond to your earlier comments and provide sufficient comfort to enable you to provide an updated and positive consultation response to the Planning Authority. However, as always, please do let me know should you require further clarification.

Naturally, I am available to speak on the matter further should you consider this to be helpful.

Yours faithfully



Richard Woods BSc MSc
Principal Transport Consultant

For and on behalf of

calibro

Enc: C&W Accessibility Report



Calthorpe Street, Banbury LA Highways Comments - Accessibility

Corstorphine & Wright

Contents



- 1.0 Accessibility
 - 1.1 Pedestrian and Cycle Connectivity
 - 1.2 Refuse Collection
 - 1.3 Deliveries
 - 1.4 Cycle Stores
 - 1.5 Cycle Hire Lockers

1.0 Accessibility

1.1 Pedestrian and Cycle Connectivity

Existing Connectivity

Calthorpe Street

- 1** Car Park Access (Level)
 - 1 x pedestrian / cycle access pavement alongside vehicle entrance
 - Designated route through car park

Marlborough Road

- 1** Car Park Access (Approx. 1 in 15)
 - 1 x pedestrian / cycle access pavement alongside vehicle entrance
 - Designated route through car park
- 2** Pedestrian Access (Stepped)
 - 1 x pedestrian stepped route at northern end of site
 - Designated route through car park

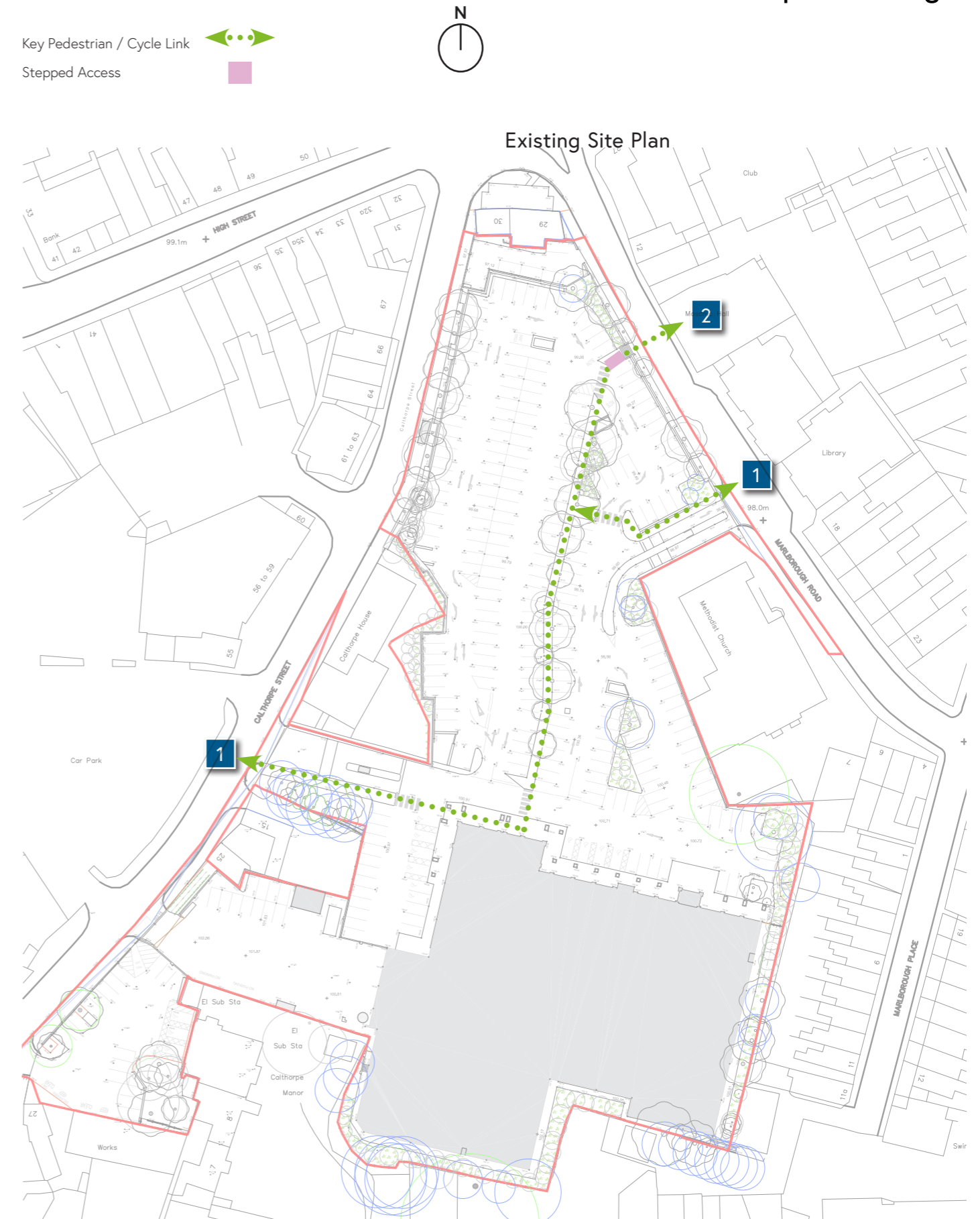

1.0 Accessibility

1.1 Pedestrian and Cycle Connectivity

Proposed Connectivity

Calthorpe Street

- 1** Smithy Walk (Level)
1 x pedestrian / cycle access
shared surface, landscaped route

- 2** Calthorpe Walk (Stepped and Ramped)
1 x pedestrian / cycle access
shared surface, landscaped route

- 3** Manor Gardens (Stepped, Platform Lift & Cycle rail)
1 x pedestrian / cycle access
shared surface, landscaped route
Level access to southern half of site
Stepped access to northern half of site / access to Marlborough Rd, with platform lift and cycle rail alternatives

Podium Steps

The podium steps traverse a level difference of approximately 1 storey through the site. Accommodating an accessible ramped access to deal with this transition would not be practical, requiring lengths of travel that would be comparable to taking the alternative ramped approach through the site instead - for example via Calthorpe Walk. It would also take up most of the landscaped public realm between the blocks or the turning heads required for adequate maintenance and emergency access, introducing brutal engineering into the setting with no overall planning advantage.

If access is specifically required to Calthorpe Gardens between Blocks A and B at the upper ground level, level access is provided off Calthorpe Street and there is a specifically provided platform lift if accessing from the northern side.

Marlborough Road

- 1** Smithy Walk (Level)
1 x pedestrian / cycle access
shared surface, landscaped route

- 2** Methodist Church (Stepped / Ramped)
1 x pedestrian route through south of church
route through play plaza

- 3** Methodist Church (Stepped / Ramped)
1 x gated connection to church grounds
route through play plaza

With a suitably-worded compliance condition, the LA can ensure that the lift is maintained for the lifetime of the development and being externally accessed, it should be available every day and for 24 hours a day.

The alternative level and ramped accesses through the site also retain good permeability for anyone not wishing to use the lift.

It is also worth noting that the existing site does not currently have any fully accessible through routes, since the access path alongside car park ramp to Marlborough Road is approximately 1 in 15 but not designed as ramped access.

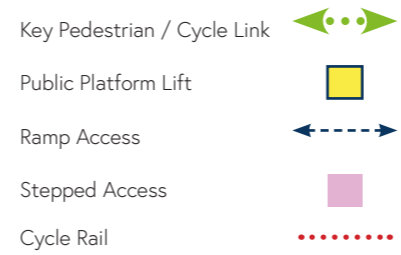

Proposed Site Plan



1.0 Accessibility

1.2 Refuse Collection

Proposed Accommodation Blocks

Blocks A & C

For Collection: (Step Free)

From Upper Ground Floor Shared Surface Area /
Turning Head accessed off Calthorpe Street

For Residents: (Step Free)

Externally From External Landscaping near Entrance
Exit from Apartments via communal circulation
(lift and stair core)

Blocks B, D, E & F

For Collection: (Step Free)

From Lower Ground Floor Shared Surface Area /
Turning Head accessed off Marlborough Road

For Residents: (Step Free)

Externally From External Landscaping near Entrance
Exit from Apartments via communal circulation
(lift and stair core) or from front door for Duplex Units

Block G

For Collection: (Step Free)

From Calthorpe Street

For Residents: (Step Free)

Externally From External Landscaping near Entrance
Exit from Apartments via communal circulation
(lift and stair core) or from front door for Duplex Units.

Town Houses

For Collection: (Step Free)

From Upper Ground Floor Collection Point

For Residents: (Step Free)

Within Rear Gardens
with step-free access to collection point for bins

Gatehouse

For Collection: (Step Free)

From Calthorpe Street

For Residents: (Step Free)

Within Ground Floor Utility / Store

Lower Ground Floor Site Plan

Upper Ground Floor Site Plan

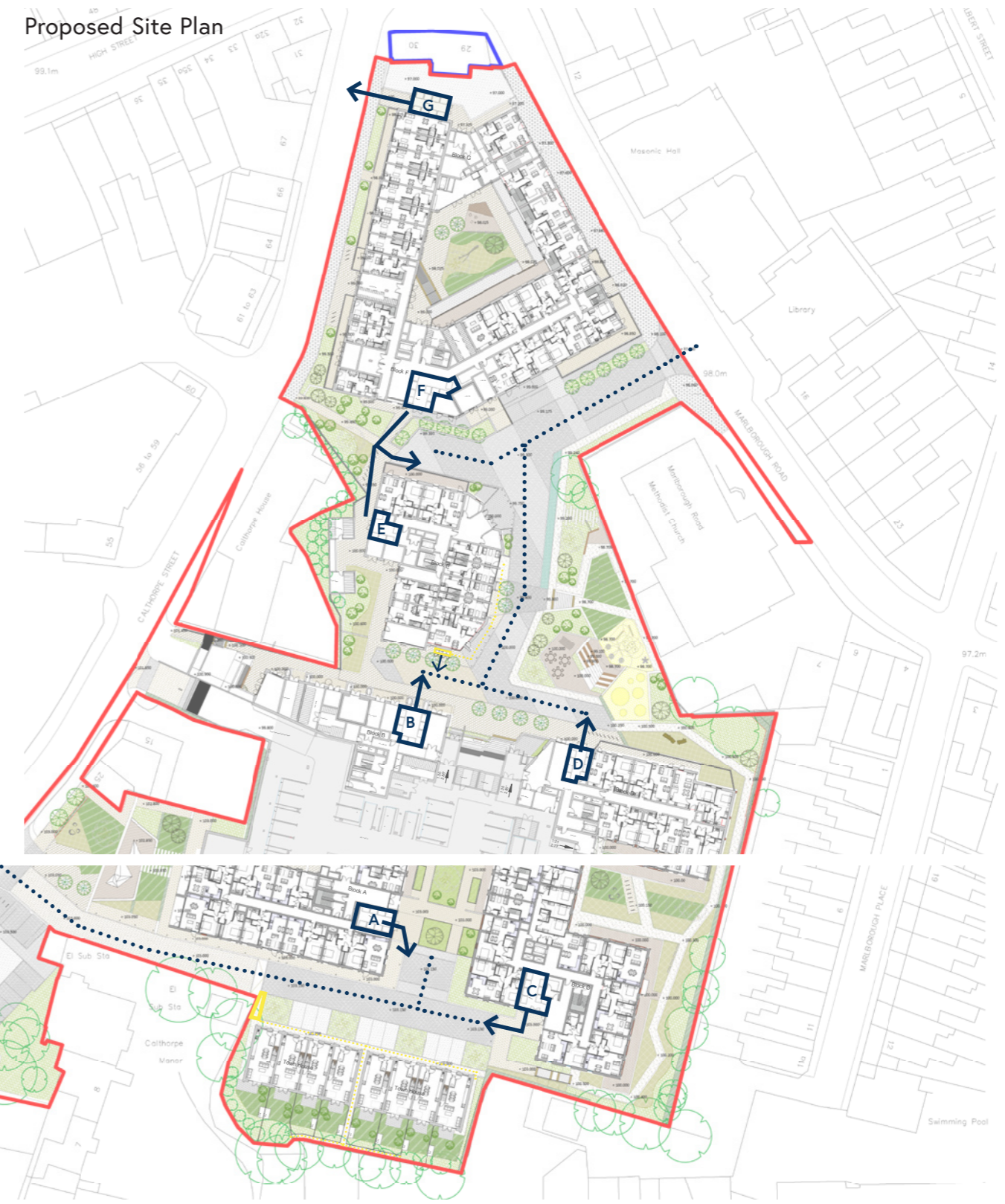
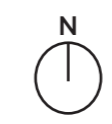
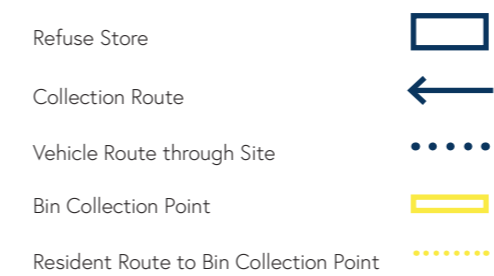

1.0 Accessibility

1.3 Deliveries

Proposed Accommodation Blocks

Blocks A & C

For Deliveries: (Step Free)

From Upper Ground Floor Shared Surface Area / Turning Head accessed off Calthorpe Street

For Residents: (Step Free)

Main Entrance

Access from Apartments via communal circulation (lift and stair core)

Blocks B, D, E & F

For Deliveries: (Step Free)

From Lower Ground Floor Shared Surface Area / Turning Head accessed off Marlborough Road

Access also from Calthorpe Street - Block F

For Residents: (Step Free)

Main Entrance

Access from Apartments via communal circulation (lift and stair core) or from front door for Duplex Units

Block G

For Deliveries: (Step Free)

From Marlborough Road and Calthorpe Street

For Residents: (Step Free)

Main Entrances

Access from Apartments via communal circulation (lift and stair core) or from front door for Duplex Units.

Town Houses

For Deliveries: (Step Free)

From Upper Ground Floor Shared Surface Area / Turning Head accessed off Calthorpe Street

For Residents: (Step Free)

Front Door Access

Gatehouse

For Collection: (Step Free)

From Calthorpe Street

For Residents: (Step Free)

Front Door Access

Lower Ground Floor Site Plan

Upper Ground Floor Site Plan



Proposed Site Plan

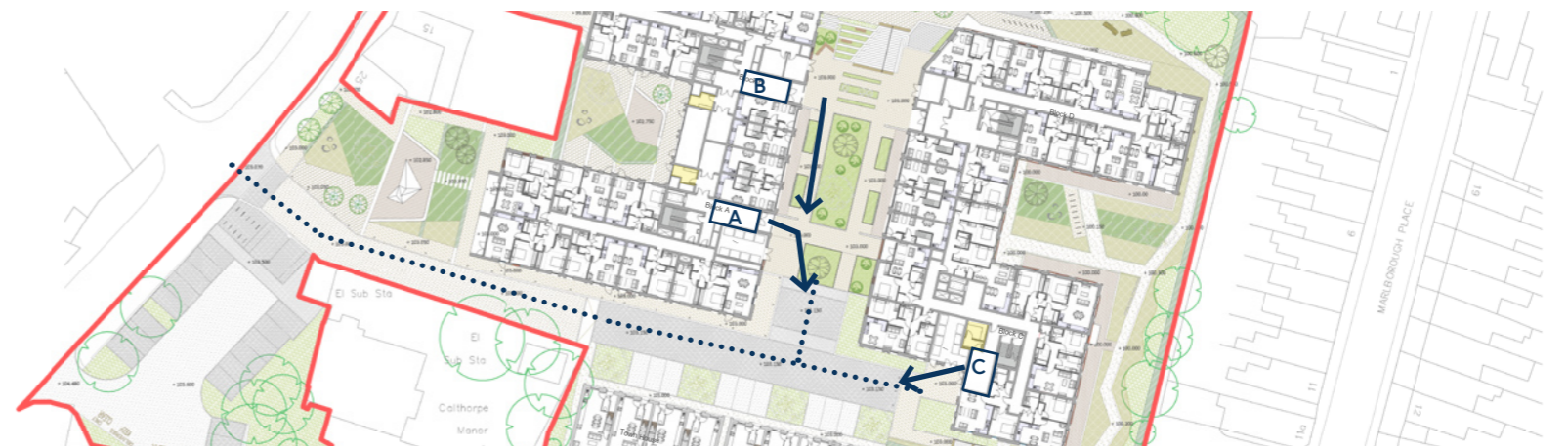
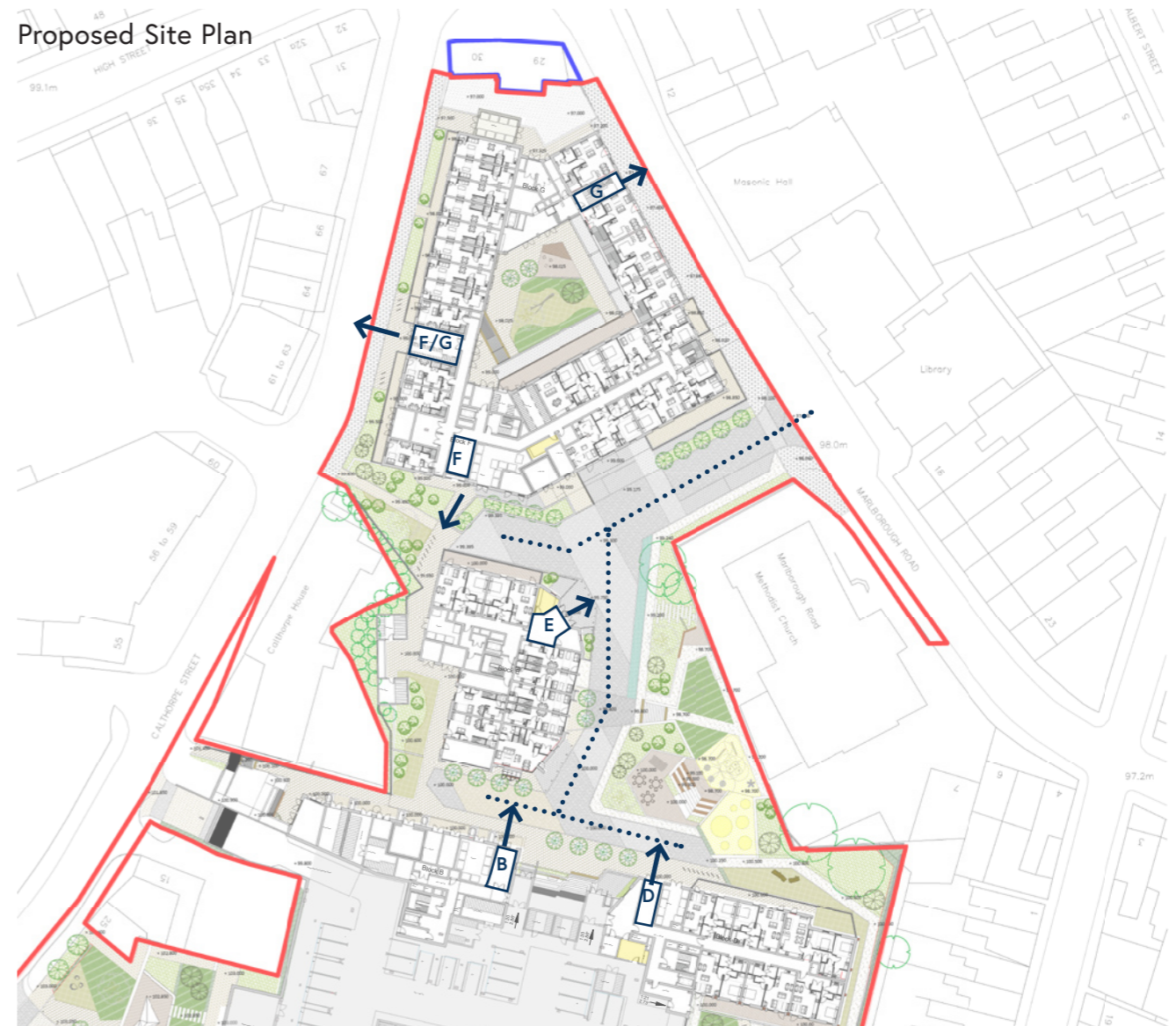

1.0 Accessibility

1.4 Cycle Stores

Overall Provision - Residents

Across Blocks A-G we understand there would be a requirement for **283 spaces**, based on the Oxfordshire Cycling Design Standards.

Since our pre-application advice, LA cycle standards have increased, and across blocks A-G would require a total of **592 spaces** - which more than doubles the required provision.

Such an increase would equate to a loss of proposed internal amenity space for conversion into stores, or a loss of external amenity and public realm to accommodate external stores. It's envisaged that these additional stores would remain empty or underutilised and therefore represent an inefficient use of space.

The requirement of 283 cycle storage spaces itself requires a significant use of space, and we have therefore proposed semi-vertical racks for more efficient stores. This type of racking is available with electric charge points and is more accessible than purely vertical racks. Residents will be accustomed to using them, whereas traditional sheffield-hoop stands are proposed for shorter stay, visitor parking.

We have however also now proposed that a number of horizontal stands are provided as an alternative option, as well as some secure points to cycle store walls that allow for accommodation of larger or more bespoke bicycles.

Under the new standards, the 4 bed townhouses would require cycle storage for 8 bicycles within each rear garden, which seems excessive and reduces private amenity. A shed for 2 cycles is therefore proposed for each townhouse in accordance with the previous standards.



CONNECTING OXFORDSHIRE



Example of typical standard single decker bike rack

Single Decker Classic 305

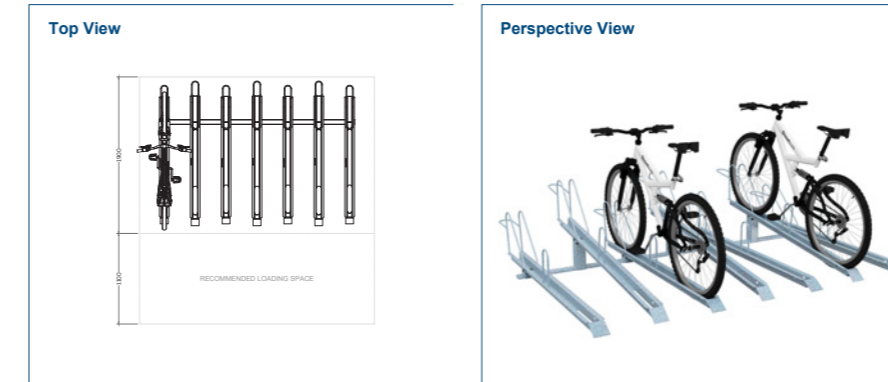

Technical information

Materials:	Mild Steel
Standard Finish:	Galvanised to BS EN ISO 1461:2009
Optional Finishes:	Powder-coating in any standard RAL colour
Configuration:	Single Sided
Bike Capacity:	Bespoke to customer specification
No. of Locking points:	3No. per bike space Front wheel, Middle locking loop & Rear Wheel
Fixing Options:	Surface Mounted
Optional Extras:	Location identifiers, anti-tamper fixings, signage
BREEAM:	Our products will assist with achieving BREEAM rating
Product Warranty:	Two years
Recommended Height:	1200mm
Benefits:	This British made two-tier rack is built to last, it requires minimal maintenance and can be space planned to fit a variety of unique locations.

Example of typical semi-vertical storage



Our Semi Vertical Bike Rack is designed for areas where space is at a premium. The cycle racks can be infinitely extended making them ideal for commercial applications; both internally and externally.

They are extremely flexible, either being placed against a wall or back to back, creating a central island and drastically increasing the usage of space.

The secure locking hoop allows for additional security with the use of a D-Lock to secure both the frame and wheels. This product has been designed to be BREEAM Compliant,

- Designed & Manufactured in Great Britain
- Mild steel racks - hot-dip galvanised to BS EN ISO 1461 : 2009
- Each channel includes a steel locking hoop for securing bicycles
- 305mm centres (standard) between each rack/channel
- Unloaded dimensions: 1785mm (height) x 1100mm (depth)
- Loaded dimensions: 2000mm (height) x 1300mm (depth)
- Includes fixing bolts and ground anchors
- Maximum of 6no. cycle spaces between legs

Cycle spaces	1B	2B+	Total
Block A	23	22	45
Block B	18	18	36
Block C	14	30	44
Block D	30	18	48
Block E	20	14	34
Block F	34	24	58
Block G	15	8	23
	154	134	288

Requirement per Block

1.0 Accessibility

1.4 Cycle Stores

Blocks A - D

REQUIREMENT - 173 SPACES

- Based on Oxfordshire Cycling Design Standards as advised through pre-application process
- Balances realistic provision with efficient use of space and provision of internal and external amenity space

PROVISION - 173 SPACES over 8 No. Stores

- Average size of store - 21.5 spaces
- Smaller stores for security and ease of access
- Accessible aisle in excess of manufacturers' recommendations
- Provision of 52 standard and 121 semi-vertical racks, additional wall-mounted stands

ACCESS

- 3 x Stores accessed externally from public realm
 - From 'Calthorpe Walk' - new link through site
 - Close to LGF entrances of Blocks B & D
 - Close to podium steps (cycle rail) with UGF access to entrances of Blocks A, B, C and D
- 5 x Stores accessed from car park
 - Separate cycle / pedestrian access to car park
 - Circulation around and on arrival to stores with cycles, separated from vehicle routes
 - Internal access to Blocks A, B, C and D

Cycle spaces	1B	2B+	Total	
Block A		23	22	45
Block B		18	18	36
Block C		14	30	44
Block D		30	18	48
Block E		20	14	34
Block F		34	24	58
Block G		15	8	23
		154	134	288

Requirement per Block

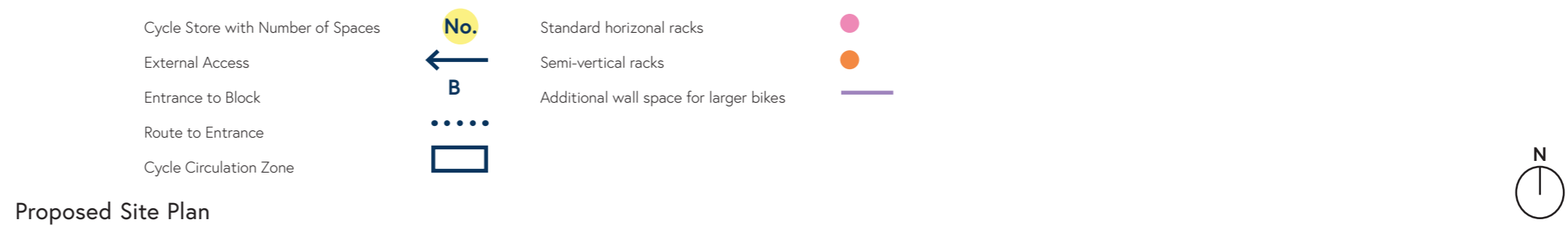

Proposed Site Plan

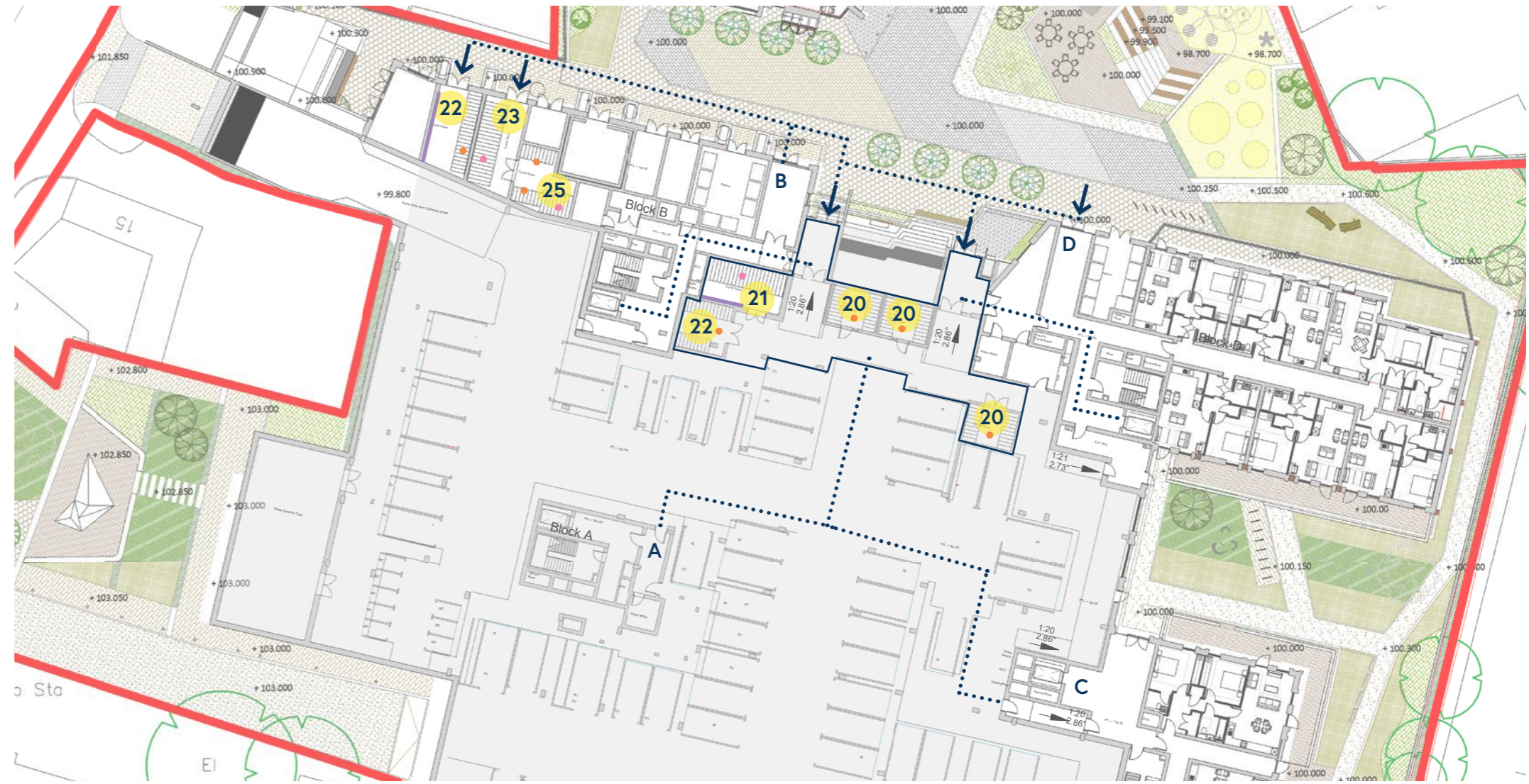

Lower Ground Floor Site Plan

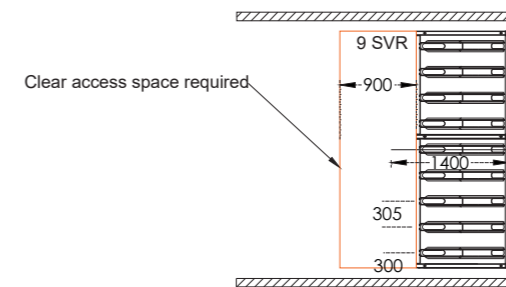
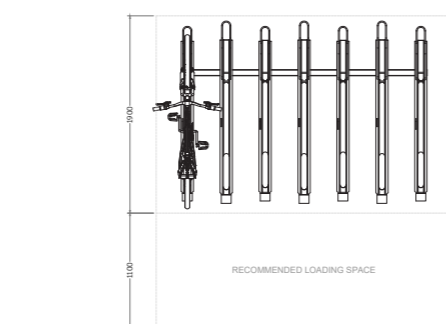

● Minimum access space required

● Standard single decker

● Minimum access space required

● Semi-vertical racks - balance efficiency with ease of access / use

1.0 Accessibility

1.4 Cycle Stores

Block E

REQUIREMENT - 34 SPACES

- Based on Oxfordshire Cycling Design Standards as advised through pre-application process
- Balances realistic provision with efficient use of space and provision of internal and external amenity space

PROVISION - 34 SPACES over 2 No. Stores

- 1 x Store with 22 Spaces
- 1 x Store with 12 Spaces
- Smaller stores for security and ease of access
- Accessible aisle in excess of manufacturers' recommendations
- Additional Space for Storage of Large Cycles
- Provision of 23 standard and 11 semi-vertical racks, additional wall mounted stands

ACCESS

- 2 x Stores accessed externally from secure courtyard
- Access from external amenity space for Block E
- Close to rear entrance of Block E
- Close to links into routes through site

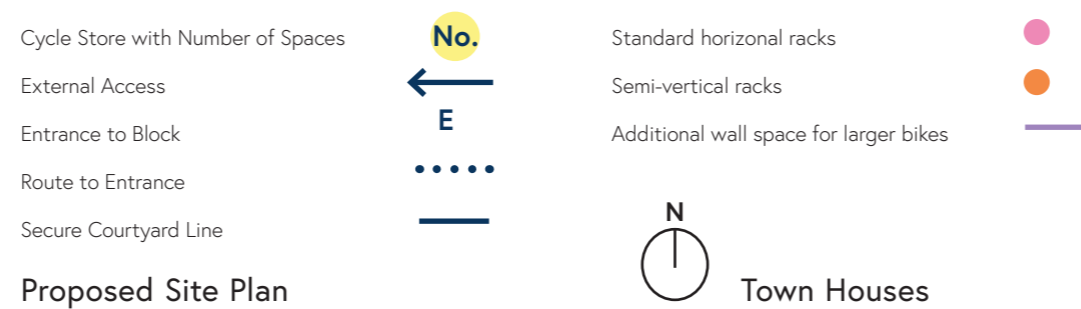

Proposed Site Plan

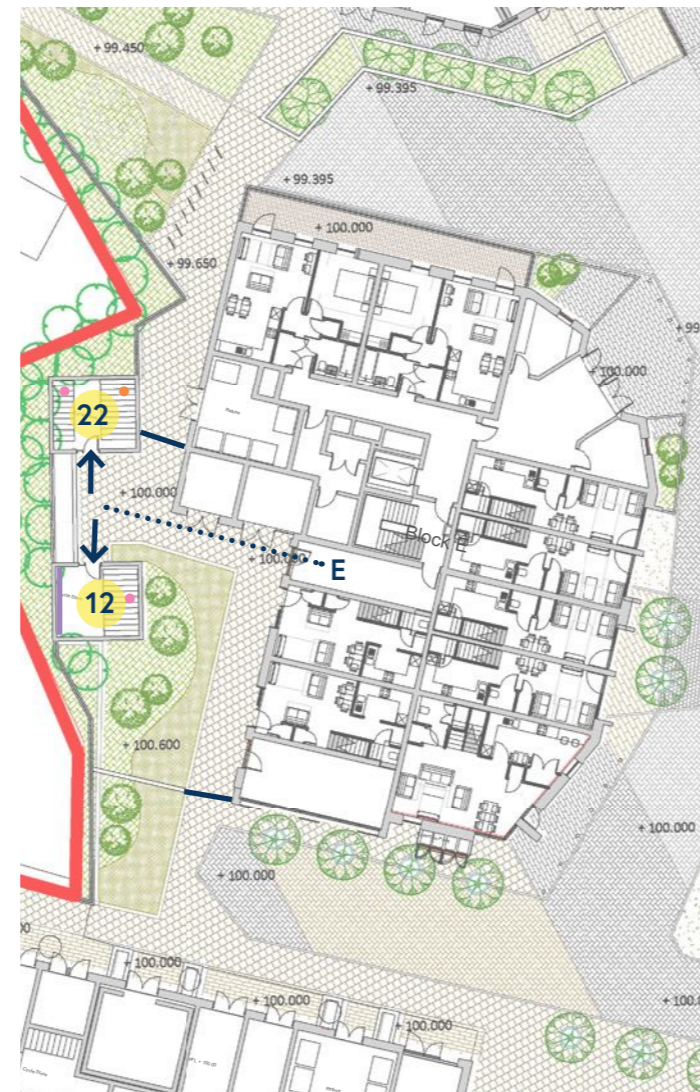

Lower Ground Floor Site Plan

Town Houses

REQUIREMENT - 16 SPACES

- Based on Oxfordshire Cycling Design Standards as advised through pre-application process
- Balances realistic provision with efficient use of space and provision of internal and external amenity space

PROVISION - 16 SPACES over 8 No. Stores

- 8 x Stores with 2 Spaces (1 store / house)
- Stores located securely in rear garden

ACCESS

- External shared, level access paths to rear gardens
- Gated access to rear paths

Gatehouse

REQUIREMENT - 2 SPACES

- Based on Oxfordshire Cycling Design Standards as advised through pre-application process
- Balances realistic provision with efficient use of space and provision of internal and external amenity space

PROVISION - 2 SPACES within GF Utility / Store

- Space for 2+ cycles
- Additional Space for Storage of Large Cycles

ACCESS

- Garage-type door access off Calthorpe Street

Cycle spaces	1B	2B+	Total
Block A	23	22	45
Block B	18	18	36
Block C	14	30	44
Block D	30	18	48
Block E	20	14	34
Block F	34	24	58
Block G	15	8	23
	154	134	288

Requirement per Block

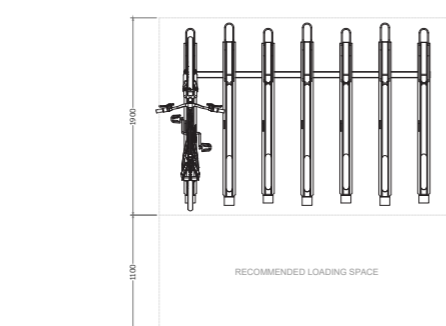

Minimum access space required



Standard single decker

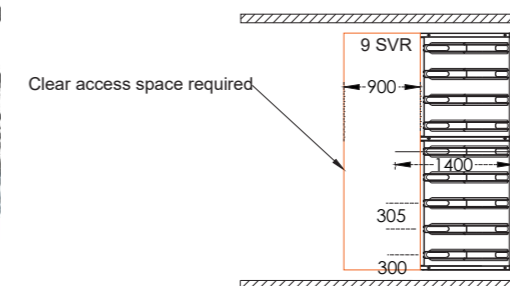

Minimum access space required



Semi-vertical racks - balance efficiency with ease of access / use

1.0 Accessibility

1.4 Cycle Stores

Blocks F & G

REQUIREMENT - 81 SPACES

- Based on Oxfordshire Cycling Design Standards as advised through pre-application process
- Balances realistic provision with efficient use of space and provision of internal and external amenity space

PROVISION - 81 SPACES over 3 No. Stores

- 1 x Store with 42 Spaces
- 1 x Store with 25 Spaces
- 1 x Store with 14 Spaces
- Smaller stores for security and ease of access
- Accessible aisle in excess of manufacturers' recommendations
- Provision of 16 standard and 65 semi-vertical racks

ACCESS

- 2 x Stores accessed externally from secure courtyard
 - Close to Block F rear / Garden Room Entrance
 - Close to Block G rear / Garden Room Entrance
- 1 x Store accessed externally from Calthorpe Street / Secure Courtyard
 - Also serves as through-route residents' access to courtyard
 - Links to external road network

- Cycle Store with Number of Spaces
- External Access
- Entrance to Block
- Route to Entrance
- Cycle Circulation Zone
- Standard horizontal racks
- Semi-vertical racks
- Additional wall space for larger bikes



Proposed Site Plan



Lower Ground Floor Site Plan

Cycle spaces	1B	2B+	Total	
Block A		23	22	45
Block B		18	18	36
Block C		14	30	44
Block D		30	18	48
Block E		20	14	34
Block F		34	24	58
Block G		15	8	23
		154	134	288

Requirement per Block

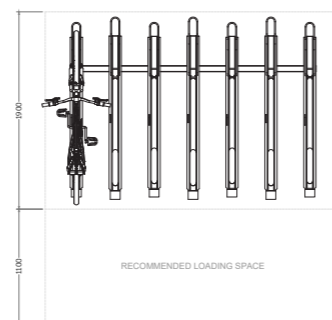

Minimum access space required



Standard single decker

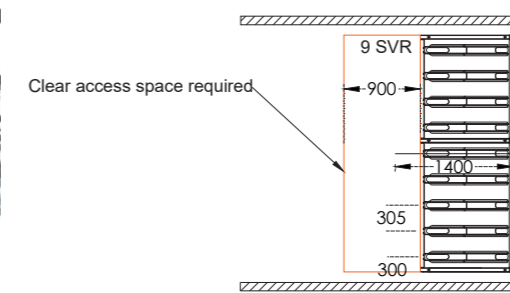

Minimum access space required



Semi-vertical racks - balance efficiency with ease of access / use

1.0 Accessibility

1.4 Cycle Stores

Visitor Parking

REQUIREMENT - 115 SPACES

- Based on Oxfordshire Cycling Design Standards as advised through pre-application process
- Balances realistic provision with efficient use of space and provision of internal and external amenity space

PROVISION - 114 SPACES over 7 No. Stores

- Sheffield-hoop type stands
- Well-overlooked

ACCESS

- Distributed well throughout the site
- Good links to surrounding network



Cycle Store with Number of Spaces

No.

Proposed Site Plan



Site Block Plan

1.0 Accessibility

1.5 Cycle Hire Lockers

Cycle Hire Lockers

As part of the Travel Plan, should additional demand for cycle storage prove necessary, cycle lockers such as Brockton Bike Hire lockers can be added.

Space for 32 lockers has been identified within the public realm landscaping as indicated on the attached plan. Should demand require further provision, there is additional space that can be used within the lower ground floor car park area to accommodate more locker bays.



Solar Powered Bike Hire Lockers - Extensions Bays of 4



Example Secure Bike Hire Lockers

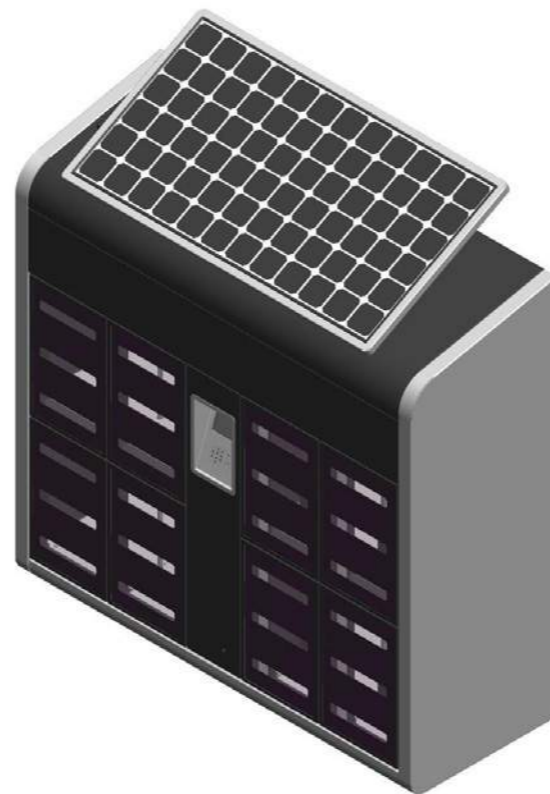

Solar Powered Bike Hire Lockers - Bay of 8



Cycle Lockers with Number of Spaces

No.

Proposed Site Plan



Site Block Plan

Corstorphine & Wright

Contact us to discuss your project

 www.corstorphine-wright.com

 contact@cw-architects.co.uk

 [corstorphine-wright](https://www.linkedin.com/company/corstorphine-wright)

 [@cwrightarch](https://twitter.com/cwrightarch)

 [corstorphinewright](https://www.instagram.com/corstorphinewright)

