

East West Rail Bicester to Bedford Improvements Construction Traffic Management Plan

Development Stage 2A1

Network Rail



Notice

This report was produced by the Alliance for the specific purpose of construction traffic management.

This report may not be used by any person other than the Alliance without the Alliance's express permission. In any event, Alliance accepts no liability for any costs, liabilities or losses arising as a result of the use of or reliance upon the contents of this report by any person other than the Alliance.

Document History

JOB NUMBER: 5187843			DOCUMENT REF: 2A1			
Revision	Purpose Description	Originated	Checked	Reviewed	Approved	Date
5	TM Amendments requested by OCC – Table 14.1 & Appendix I – total of 4 drawings only.	AI	TC	AI	JB	02/07/2020
4	Amendments requested by OCC	AI	TC	AI	JB	10/06/2020
3	Amendments requested by OCC	ML	TC	AI	IJ	20/05/2020
2	Second Issue – Internal review	ML	TC	AI	IJ	20/05/2020
1	First Issue	ML	TC	AI	IJ	21/02/2020



Contents

Section	Page
Glossary	6
1. Introduction	7
1.1 Overview	7
1.2 Development Stages	7
1.3 Overview of construction compounds	8
1.4 Planning conditions	8
1.5 Condition 15a details	9
1.6 CTMP purpose	10
1.7 Report structure	11
Part A – General principles	12
2. Methods of working	13
2.1 General principles	13
2.2 Site control and security measures	13
2.3 Time restrictions	14
2.4 Public highway parking and staff travel	14
3. Roles and responsibilities	15
3.1 Implementation	15
3.2 Supply chain engagement	15
3.3 Near miss reporting	15
3.4 Key personnel	15
3.5 Works Supervisor/Foreman	16
4. Construction traffic	18
4.1 Overview	18
4.2 Access points	18
4.3 Construction access routes	19
4.4 Control of construction traffic	19
4.5 Vehicle identification	20
4.6 Vehicle types	20
5. Public rights of way	22
5.1 Overview	22
6. Traffic management	23
6.1 Traffic management principles	23
6.2 Road control principles	23
7. Signage principles	26
7.1 Principles of signage	26
7.2 Erection and location of signs	27
7.3 Advance and intermediate advance warning signs	27
7.4 Site access signage	27
7.5 Traffic controller's check	27

7.6	Termination taper	28
8.	Delivery management	29
8.1	Overview	29
8.2	Audit and performance monitoring	29
8.3	Communication and engagement	29
8.4	Movement of excavated materials and abnormal loads	30
8.5	Movement of unscheduled loads	30
Part B – Development Stage specific information		31
9.	Development Stage and compound description	32
9.1	Compounds	32
9.2	Access points	32
9.3	Haul road crossing points	33
9.4	Charbridge Lane developments	33
9.5	Existing and Committed Developments	33
9.6	Permitted Development	34
10.	Key personnel	35
11.	Construction Access	36
11.1	Overview	36
11.2	Access restrictions	36
11.3	Pre-condition survey	36
11.4	Highway improvement works	37
12.	Compound Details	38
12.1	Overview	39
12.2	Layout	39
12.3	Parking	39
12.4	Operations	39
12.5	Visitors	40
12.6	Site hoarding	40
12.7	Site storage	40
12.8	Site specific control measures	40
13.	Signage strategy	41
13.1	Overview	41
14.	Traffic management	43
14.1	Overview	43
15.	Public rights of way	44
15.1	Public rights of way overview	44

Tables

Table 1.1: Overview of Development Stages	7
Table 1.2: Sub-conditions of Condition 15a	9
Table 6.1: Summary of recommended taper lengths	24
Table 11.1: Overview of Highways Improvement Works Drawings	38
Table 13.1: 2A1 Signage Strategy Drawings Submissions Register	42
Table 14.1: 2A1 Traffic Management Drawings Submissions Register	43
Table 15.1: 2A1 PRow Design Drawings Submissions Register	44

Inserts

Figure 4-1 Drawing of a typical 40t 4-axle wagon, used for granular materials	20
Figure 4-2 Drawing of a typical 5t rigid pickup	21
Figure 5-1 The ETON process	22
Figure 6-1 Typical temporary traffic management signage and barrier examples	23
Figure 6-2 Typical road works control layout plan	24
Figure 11-1 Location of Highways Improvement Works in Development Section 2A1	37
Figure 13-1 2A1 Route Signage Strategy Geographical Extent	41

Appendices

Appendix A – Construction Access Routes
Appendix B - Indicative Roadspace and PRow Booking Schedule
Appendix C – Development Stage Layout
Appendix D – GA Plans
Appendix E – Pre-Commencement Survey
Appendix F – Compound Layout
Appendix G – Offline Highways Improvement Works
Appendix H – Construction Route Signage Strategy
Appendix I – Traffic Management Drawings

Glossary

Term	Description
ACS	Access Control System
Alliance	East West Rail Alliance
BBC	Bedford Borough Council
BC	Buckinghamshire Council
CBC	Central Bedfordshire Council
CDC	Cherwell District Council
CLOCS	Construction Logistics and Community Safety is an accreditation scheme
CSCS	Construction Skills Certification Skills
CTMP	Construction Traffic Management Plan
Development Stages	A sub-division of the Project, based around the programme of works
DMS	Delivery Management System
ETON	Electronic Transfer of Notice
FORS	The Fleet Operator Recognition Scheme is an accreditation scheme for fleet operators
HGV	Any vehicle over 7.5t
LANTRA	An awarding body for land-based industries
LGV	Any vehicle up to 7.5t excluding cars
MKC	Milton Keynes Council
NMU	Non-Motorised User
OCC	Oxfordshire County Council
PPE	Personal Protective Equipment
Project	The East West Rail Scheme - Phase 2
PROW	Public Right of Way
PTS	The Personal Track Safety scheme is an essential qualification for workers to enable them to work on or near any line owned or managed by Network Rail
RFFP	Reasonably Foreseeable Future Project
SIA	The Security Industry Authority is the statutory organisation responsible for regulating the private security industry in the UK
TWAO	Transport and Works Act Order
Voyage Control	A delivery management system which is to be used for the Project
VRCC	Volker Rail Control Centre

1. Introduction

1.1 Overview

- 1.1.1 Network Rail Infrastructure Limited (NR) submitted The Network Rail (East West Rail Bicester to Bedford Improvements) Order application, under the Transport and Works Act 1992, for construction and operation of Phase 2 of the East West Rail (EWR) Project. From this point forward, the Order is referred to as the TWAO. The TWAO application was accompanied by an Environmental Statement (ES), in accordance with The Transport and Works (Applications and Objections Procedure) (England and Wales) Rules 2006.
- 1.1.2 The Project runs between Bicester in the west to Bedford in the east, with a spur south to Aylesbury and a short spur north to Bletchley and comprises approximately 78km of existing railway or railway alignment.
- 1.1.3 The Project runs through the following local authority areas:
- Oxfordshire County Council (OCC)
 - Buckinghamshire Council (BC)
 - Cherwell District Council (CDC), within OCC
 - Milton Keynes Council (MKC), a unitary authority
 - Central Bedfordshire Council (CBC), a unitary authority; and
 - Bedford Borough Council (BBC), a unitary authority.

1.2 Development Stages

- 1.2.1 The Alliance has divided the Project into 15 Development Stages. These Development Stages, the construction compounds contained within each and the relevant local authorities are set out in **Table 1.1**. The table also confirms how the different CTMPs will support the different Development Stages.

Table 1.1: Overview of Development Stages

Development Stage	Compound	CTMP	Planning Authority	Highway Authority
2A1	A1	Yes	CDC	OCC
2A2	A2	Yes	CDC & BC	BC
2A3	A3	Yes	BC	BC
2A4	A4	Yes	BC	BC
2B1	B1	Yes	BC	BC
2B2	B2	Yes	BC	BC
2B3	B3	Yes	BC	BC
2B4	B4	Yes	BC	BC
2B5	B5	Yes	BC	BC
2B6	B6	Yes	BC & MKC	BC, MKC
2C1	C1		MKC	MKC

2C2	No construction compound (as per TWAO)	A single CTMP will be produced to cover 2C1 and 2C2		
2D – Main Works	D1, D2	A single CTMP will be produced to cover 2D – Main works and 2D – Platform Extensions	MKC & CBC & BBC	MKC, CBC, BBC
2D – Platform Extensions	No construction compound			
2E	E3, E4, E5	Yes	AVDC	BBC

1.2.2 The section where the Project interacts with the HS2 works is not included as a Development Stage and does not require a Construction Traffic Management Plan (CTMP) to be produced as part of this scope of work.

1.3 Overview of construction compounds

1.3.1 Compounds will be divided into two categories: strategic compounds and satellite compounds.

1.3.2 Strategic compounds will be used as primary control and coordination points for the Development Stage. Strategic compounds will have comprehensive welfare and support systems and functions in place such as cafeteria, nurses station, fuel storage etc.

1.3.3 Construction personnel will be predominately based at the strategic compounds. Personnel will be allocated to the most appropriate strategic compound for the Development Stage at which they will work (i.e. with direct access into the Development Stage working area).

1.3.4 Satellite compounds will be designed to serve as primary assembly, storage and laydown areas for tasks and structures within the Development Stage. Satellite compounds will have less comprehensive office and welfare facilities and are primarily control points for the day-to-day construction personnel. A smaller number of construction personnel will be based at satellite compounds.

1.4 Planning conditions

1.4.1 The TWAO application was submitted to the Secretary of State for Transport in July 2018 which has subsequently appointed an inspector to conduct a Public Inquiry into the application. An outcome of the Public Inquiry was a set of planning conditions proposed to be attached to deemed planning permission (Inquiry Document NR286).

1.4.2 The two planning conditions which are most relevant to the Construction Traffic Management Plan (CTMP) programme are summarised below:

- Condition 2, stating that:

No development shall commence until a written scheme setting out the division of the development into individual stages has been submitted to and approved in writing by the local planning authorities. The scheme shall include details of all land to be occupied permanently or temporarily during the construction of each stage or part thereof. The development shall thereafter be carried out in accordance with the approved written scheme.

- Condition 15 a), stating that:

No stage of the development is to commence within the area of a local planning authority until a Construction Traffic Management Plan (CTMP) has been submitted to and approved in writing by the relevant local planning authority.

1.4.3 This CTMP addresses these conditions and sets out how each of the sub-conditions will be discharged in each of the Development Stages.

1.5 Condition 15a details

1.5.1 Condition 15a is divided into 17 sub-conditions, each relating to a specific aspect of construction traffic management. These sub-conditions are shown in **Table 1.2**.

1.5.2 **Table 1.2** also shows the section or sections within this CTMP that specifically address the relevant planning sub-condition.

Table 1.2: Sub-conditions of Condition 15a

Item	Sub-condition	Section
i)	Details of construction access routes including access and egress points onto the public highway, including visibility splays, width, radii, fencing and gates	4, 11, 12
ii)	Prohibited routes for construction traffic	11
iii)	Any time restrictions imposed on any routes	2
iv)	Temporary road and Public Right of Way (PROW) closures and diversions	5, 15
v)	A signage strategy for each construction access route adopting the principles set out on the following drawings: 133735_2A-EWR-OXD-CC_A4-DR-CH-010301 133735_2A-EWR-OXD-CC_A4-DR-CH-010302 133735_2A-EWR-OXD-CC_A4-DR-CH-010303 133735_2A-EWR-OXD-CC_A4-DR-CH-010304 133735_2A-EWR-OXD-CC_A4-DR-CH-010305 133735_2A-EWR-OXD-CC_A4-DR-CH-010306 133735_2A-EWR-OXD-CC_A4-DR-CH-010307 133735_2A-EWR-OXD-CC_A4-DR-CH-010308 133735_2A-EWR-OXD-CC_A4-DR-CH-010309 133735_2A-EWR-OXD-CC_A4-DR-CH-010310 133735_2A-EWR-OXD-CC_A4-DR-CH-010311 133735_2A-EWR-OXD-CC_A4-DR-CH-010312 133735_2A-EWR-OXD-CC_A4-DR-CH-010313	7, 13
vi)	Details of the audit and performance monitoring for construction traffic to ensure their adherence to the stated routes and restrictions	8
vii)	Traffic control measures (including details of traffic signal installations)	6, 7, 14
viii)	Site specific controls in consideration of the potential nuisance (noise, vibration, mud and dust)	3, 4, 12
ix)	Prohibition of parking of any construction site vehicles along the public highway	2
x)	Detailed plans of highway improvements for safety, capacity, accessibility and resilience along any routes where considered necessary by the local planning authority including but not limited to details of passing bays, junction alterations, areas of carriageway widening, highway structures, footways, cycleways, drainage, signage, Intelligent Traffic Systems, road markings and carriageway strengthening required as a result of construction of the works with a timetable for implementation of the improvements and removal where appropriate	11
xi)	Details of site hoarding	2, 12
xii)	Details of control of access/site security	2, 3, 4, 12

xiii)	Parking, including for site operatives, turning, loading and off-loading facilities	2, 12
xiv)	Pre-condition survey of the existing highway network to be used for construction traffic to be undertaken prior to the construction route being brought into use and proposals for inspection and repair of any damage to the highway network attributable to construction traffic	5, 11
xv)	Proposals for the reinstatement of PROWs where used for construction traffic	5, 15
xvi)	Details of the storage of materials, plant and machinery	2, 12
xvii)	Details of the management and handling of the movement of any excess excavated material and any new imported material	8, 12

1.6 CTMP purpose

- 1.6.1 This CTMP addresses the systems and procedures that should be followed to warn, inform and guide road users and members of the public through or around all works related to the Project.
- 1.6.2 All employees, contractors, management staff and any other person with any involvement in the construction of the project regardless of employer (from this point forward referred to as construction personnel) must adhere to this CTMP.
- 1.6.3 The Alliance has a duty to provide a workplace that does not put at risk the health and safety of any member of the construction personnel and ensures that everyone can go home safe and well every day.
- 1.6.4 To ensure this, the Alliance will be relentless in protecting their most valuable asset: everyone that works for and with us.
- 1.6.5 Every year a number of people are killed or injured by vehicles within construction industry. This CTMP provides practical guidance on the planning of these issues, the control measures that will be implemented and highlights the points for consideration and necessary actions.
- 1.6.6 Avoiding hazards and controlling the risks associated with construction traffic is essential. Therefore, this CTMP will obligate and promote the following:
- Planning and management for construction access within the relevant Development Stage
 - The elimination of reversing, where possible
 - Safe driving and working practices
 - Protection of the public
 - Adequate vision and line of sight
 - The provision of signs and barriers; and
 - Adequate parking and offloading/storage areas.
- 1.6.7 Therefore, we believe that this CTMP should embrace a best-for-project approach and should be developed for the Alliance by the Alliance.
- 1.6.8 In addition to Alliance personnel, all construction personnel have a duty to take reasonable steps to ensure the safety of:
- Themselves
 - People working under their supervision or command
 - People working around them
 - Property belonging either to themselves or to some other person or organisation; and
 - The general public.
- 1.6.9 This CTMP will be developed, implemented and maintained in accordance with core EWR principles as set out in the following:

- EWR Charter
- Sustainability Policy
- Health and Safety Policy
- Quality Policy; and
- Collaborative Working Policy.

1.6.10 This CTMP is a live document and will be reviewed on a regular basis to ensure that any changes to the Project design, compound design, the local road network and highway condition or any other significant change can be incorporated into the CTMP and be addressed at an early stage.

1.7 Report structure

1.7.1 This CTMP is divided into three main parts:

- Part A – General principles. This part of the report will set out the general and guiding principles, and these shall remain consistent for each Development Stage.
- Part B – Site specific details. This part of the report will include specific aspects of construction traffic management planning which are individual to each Development Stage and therefore require bespoke mitigation measures.
- Appendices which contain annexed information including drawings.

Part A – General principles

2. Methods of working

2.1 General principles

- 2.1.1 For the purposes of this report, traffic management refers to the management of both vehicles and non-motorised users (NMUs) on the public highway. Traffic management shall be undertaken in a manner that promotes the safety of all staff, subcontractors and the public, and ensures that road and footway users are not exposed to foreseeable risks.

2.2 Site control and security measures

Site access control

- 2.2.1 The perimeter of each works site will be secured by security fencing and hoarding, and security gates will be installed at all site access points. Security gates will be closed at all times except for providing access to a scheduled delivery or to allow access to construction personnel.
- 2.2.2 A gateman will be appointed to control access to and from each site. It will be the responsibility of the gateman to guide incoming traffic and is aware of any egressing vehicles. Construction vehicles delivering to the site will be under continuous control of the gateman.
- 2.2.3 No Vehicle Marshalls or gateman will enter the live carriageway as compound entrances are offset from the main carriageway.
- 2.2.4 The gateman will be required to wear highway-compliant high-visibility clothing. If deemed necessary, more than one gateman will be allocated.
- 2.2.5 All deliveries of plant, materials and structures to the compound will be booked in and out via the delivery management system (Voyage Control).
- 2.2.6 Vehicles will enter and exit site in a forward direction; hence avoiding the need for reversing outside of the site boundary.
- 2.2.7 Loading and unloading will be via a self-contained lorry lifting device where available (e.g. Hiab or Moffet).
- 2.2.8 If a self-contained lifting device is not available, then appropriate equipment and space for handling individual loads will be provided at each compound. No materials or deliveries will be managed in an unsafe manner.
- 2.2.9 Lifting will be undertaken in accordance with a “lifting assessment” completed by the lifting supervisor.
- 2.2.10 All deliveries drivers will require to wear full PPE when on site and will be provided with a summary of site rules issued / advised at sign in.

Personnel access

- 2.2.11 Security gates will be used to ensure that only authorised personnel and deliveries can enter and will remain closed at all other times. This will include the use of an electronic access control system (ACS).
- 2.2.12 In addition to controlling access, the ACS will provide up-to-date and accurate accounting for on-site personnel which will assist with controlling health and safety and providing a Fire Emergency Preparedness Plan.
- 2.2.13 Personnel requiring access to the site for reasons other than carrying out physical construction work and who do not possess a valid permanent security pass will be treated as a site visitor.
- 2.2.14 All visitors will be granted access by appointment only and must in all cases be authorised by a senior manager at each site. The senior manager will provide site security with a signed visitors' form prior to the visit. This will reduce the number of non-essential or unauthorised visits.
- 2.2.15 All visitors, except for authorised collection or delivery drivers shall be the responsibility of the permanent pass holder host at all times whilst on site.

- All visitors must sign in at security.
- Always use the pedestrian walkways, access gates are provided for a safe and easy access to site office.
- Compounds will be segregated into non-PPE & PPE areas. Personnel will not be allowed access into PPE areas without the appropriate equipment as per network rail standards.
- EWRA will provide a robust system of inductions, safety briefings, task briefing statements and work package plans for any works.
- Visitor inductions can be arranged but will require an inducted escort at all times when on the project if available.
- A dedicated site security guard(s) will be in control of the site access and site security to ensure no members of the public can enter the site without authorisation from the gateman.

Pedestrians access routes

- 2.2.16 Safe pedestrian access routes between car parking locations, access points, work areas, site offices and welfare facilities will be provided within all construction compounds and work areas.
- 2.2.17 Where pedestrian and vehicle routes interact, appropriate crossing points and segregation will be provided.
- 2.2.18 Pedestrians accessing the construction compounds and work areas are required to wear suitable PPE at all times. This is an Alliance-wide requirement for all construction personnel.

2.3 Time restrictions

- 2.3.1 All construction works will be carried out during the working hours of:
- 07:00 to 18:00 Mondays to Fridays
 - 08:00 to 16:00 on Saturdays.
- 2.3.2 Work undertaken outside these hours, such as the delivery of abnormal loads, requires submission of written notice to the relevant stakeholders. Any site-specific hours of operation will be outlined in Section B. No works will be conducted outside of these hours without consent from the relevant Highway Authority.

2.4 Public highway parking and staff travel

- 2.4.1 Parking will be provided within the construction compound. At no time will construction personnel, including contractors and suppliers, be authorised to park outside of the site boundaries, including on the public highway, unless prior permission has been granted by either the relevant landowner or the local highway authority.
- 2.4.2 On-site parking will be managed to ensure safety of all personnel. Parking terms and regulations will be clearly displayed using signage displayed in the immediate vicinity of the parking provision.
- 2.4.3 Construction personnel will be encouraged to travel to the construction compound using sustainable modes of transport, where viable. Cycle parking will be provided at all strategic construction compounds and safe pedestrian access between the access point and the staff welfare facilities / offices.
- 2.4.4 Where possible, construction personnel and any other visitors will be encouraged to travel via sustainable methods. To act as a further incentive to encourage sustainable travel, where appropriate, transportation between local hubs such as railway stations and construction compounds will be provided (not limited to Alliance personnel).

3. Roles and responsibilities

3.1 Implementation

3.1.1 The implementation of this CTMP is mandatory and applies to all Development Stages.

3.1.2 To implement this plan effectively, the Alliance will:

Communicate the details of this plan to all construction personnel on site during a mandatory site induction. This training will be recorded and provided to the Safety Advisor

Reiterate aspects of the CTMP as required during regular pre-start meetings, tool box talks, and other necessary occasions

Develop a Vehicle Movement Plan, where required, for specific areas of the construction site

Place a copy of the relevant Vehicle Movement Plan at each entry gate for all construction personnel to review if required; and

Ensure that all plant operatives are provided with a copy of the Vehicle Movement Plan related to their role in the Work Area.

Ensure CTMP's are reviewed regularly and updated if required.

3.1.3 The minimum standard of vehicles that any contractor or supplier shall use to supply EWR2 is membership and certification within the FORS/CLOCKS scheme.

3.1.4 All Site Security Staff shall be SIA licenced officers.

3.1.5 All construction personnel, accessing the works area (not including the compound), shall hold an appropriate CSCS or PTS certification.

3.1.6 All Traffic Management personnel shall be LANTRA qualified.

3.2 Supply chain engagement

3.2.1 In addition to the delivery management system (DMS), in this case Voyage Control, the initial CTMP and any future amended CTMPs will be distributed to organisations / personnel in the supply chain to ensure that Construction Access Routes and traffic management schemes are adhered to. This will be a requirement within tender packages and tenderers will be obligated to demonstrate compliance.

3.3 Near miss reporting

3.3.1 Volker Rail Control Centre (VRCC) is currently used to report all Near Misses and Close Calls on the Project. This will be extended to cover any incidents relating to deliveries to the construction compounds allowing formal recording, investigation and trend analysis of incidents to be undertaken.

3.4 Key personnel

3.4.1 Key personnel holding a duty of care for the planning and delivery of site activities include:

Management team

- Section Delivery Lead
- Construction CRE
- H&S Adviser
- Programme Logistics Manager; and

Site team

- Construction Manager
- Section Logistics Manager.
- Compound Security
- Supervisor/Foreman
- Gateman

3.4.2 Site-specific details are provided in Section 11.

3.5 Works Supervisor/Foreman

3.5.1 The Works Supervisor/Foremen have responsibilities for two areas; the Work Area and the construction personnel under their control and are responsible for ensuring that the following minimum standards and requirements are delivered.

Works area

General construction traffic management

- A documented construction traffic management risk assessment is completed by the Works Foreman and the procedures and control measures are implemented on site.
- All highways-related works do not commence until all signage is in place, even in an emergency it is essential that safety is observed for both construction personnel, traffic and NMUs.
- Written permission is obtained from the relevant authority before any construction personnel commence any work in a road reserve

General works area

- All road users and construction personnel can proceed with their respective undertakings safely and with minimum inconvenience to the general public.
- All site related works are correctly fenced and sign-posted using the relevant approved signs.
- All signs and devices used are in good condition.
- All signs are removed at the completion of the work.
- All lamps are switched off during daylight hours and checked at night time to confirm they are working and correctly aligned.
- If any person is injured, the incident is reported to the Construction Manager and the relevant authorities.

Accident and incident reporting and investigation procedure

In the event of an incident, the following information is recorded using the Accident & Incident Reporting and Investigation Form Template

- Names and addresses of those involved.
- Names and addresses of any witnesses.
- Actual types of signs and devices at the site.
- Photographs of signs and devices at the site at the time of the incident.
- Details of the surface and the width dimension of the travelled path.
- Details of any hazard at the site.
- Details of the prevailing weather.

Construction Personnel

- Workers are competent to work on or near highways.
- Workers have a high awareness of traffic safety issues.
- Workers are informed of the public relations aspect of their work and instructed they should not allow themselves to be provoked by members of the public.

3.5.2 Where required, all workers have access to and use the following safety equipment and PPE:

- High visibility vest or shirt.
- High visibility trouser
- UV protection eyewear and sunscreen (SPF 30 standard or better).
- Wide brimmed hat/ safety helmet.
- Steel cap safety footwear.
- Appropriate clothing to protect against UV radiation.
- Hearing protection (where appropriate).
- Eye protection (where appropriate).

3.5.3 The gateman or designated person at remote sites will be responsible for ensuring that the condition of the access track and public road is not affected either by increased use or deposits of mud or debris from the work site. The gateman will also be responsible for contacting the supervisor should the provisions in place to prevent this become insufficient.

3.5.4 The gateman or designated person at remote sites will be required to wear EWR/NR compliant high-visibility clothing and a detailed risk assessment and task briefing will be developed for this operation.

3.5.5 All construction personnel carrying out work activities on or immediately adjacent to the site shall:

- Always take reasonable care for their safety and that of those around them; etc.
- Follow the applicable requirements of this CTMP.
- Prior to proceeding with any work, contact their supervisor or an Alliance team member for clarification of any requirement applicable under this CTMP, if they are uncertain of what is required or how it is implemented.
- Always obey the applicable highways rules for pedestrians and drivers.
- Always follow safe driving practices, including using the correct thoroughfare in accordance with any posted speed limits and safety requirements in a manner that does not put at risk their or any other person's (e.g. passengers, fellow construction personnel or members of the public) safety at risk

4. Construction traffic

4.1 Overview

- 4.1.1 All HGVs and LGVs travelling to construction compounds will use the designated Construction Access Routes and will be required to use the EWRA Voyage Control delivery management system (DMS).
- 4.1.2 Heavy Good Vehicles (HGVs) and Light Good Vehicles (LGVs) are limited to predefined Construction Access Routes. The construction workforce, both staff and operatives, will not have any restrictions on the routes to the office / welfare locations however compound specific travel plans have been developed to encourage the use of the most appropriate routes. However, wherever appropriate, Staff traveling via other modes of transport will also be encouraged to use the agreed Construction Access Routes.
- 4.1.3 HGV trips for plant and material deliveries will travel directly to the compound, local access point or structure via a designated route.
- 4.1.4 LGVs will be used to travel between the various access points and for some of the smaller supply chain deliveries from the wider highway network.
- 4.1.5 Where possible, all deliveries will be planned to avoid peak hour traffic (morning and afternoon).
- 4.1.6 All traffic controllers shall always be suitably accredited and wear the required PPE.
- 4.1.7 Staff (office works and administrators, supervisors and engineers) and operatives (construction workers) will travel to compounds only; and will be transferred from compounds to local access points and work areas using LGVs (minibuses).
- 4.1.8 Where practicable, it is proposed to use the existing rail network and the newly constructed rail network for delivery of materials. It is anticipated that this would predominantly be related to bulk rail system materials such as rail, sleepers and ballast.
- 4.1.9 The scheme will use the local highway network to access various points along the project corridor referred to as access points. These are classified as either compound access points, local access points or structure access points.

4.2 Access points

Compound access points

- 4.2.1 Compound access points act as the main points of entry and exit from a compound. They are strategically positioned to ensure good accessibility and efficient movement to and from the compound for personnel, equipment and materials.

Local access points

- 4.2.2 Local access points will predominantly be used to access the project corridor from the public highway between the compound locations to deliver materials to the point of use. Deliveries may come from adjacent compounds or direct from the external supply chain.

Structure access points

- 4.2.3 Structure access points are anticipated to be used for short durations. They will enable the construction of a specific structure or asset (for example - to undertake works to a level crossing, at new footbridge location or as access to a station). The materials and plant to construct the asset will be delivered directly to the location and retrieved on completion. Structure access points will not be used to access along the Project corridor and are therefore limited to deliveries associated with the asset.

4.3 Construction access routes

- 4.3.1 Construction HGVs and LGVs will be limited to pre-defined routes between the strategic road network (e.g. motorways) and the construction compounds. The designated Construction Access Routes are shown in Appendix A.

4.4 Control of construction traffic

- 4.4.1 Access will be restricted along the project corridor (otherwise known as the EWR trace) to allow construction operations to progress without the constraint of maintaining access. The closest access point to the activity should always be used to limit the extent of distance travelled along the project corridor required. Where access along the project corridor cannot be avoided a general 20mph site limit for all site traffic will be in place, this will be reduced to 10mph in some locations where work operations or physical constraints require
- 4.4.2 Article 4, Paragraph 2 of the EWR Order 2020 disapplies Section 73B of the New Roads and Street Works Act 1991, which means that the project does not have to adhere to time restrictions imposed on routes. Planning condition 15(a)(iii) calls for the CTMP to include "any time restrictions imposed on routes", but in line with the powers afforded by the Order it is not the project's intention to impose any such restrictions.
- 4.4.3 However, the East West Rail Alliance recognises that traffic on the Bicester perimeter roads is a concern to both the Local Highways Authorities as well as to the Alliance. The Alliance proposes that whilst there can be no impact on the authorities and freedoms afforded by the EWR Order 2020, the Alliance shall make continuous efforts to avoid scheduling Heavy Goods deliveries before 0900hrs on a weekday. The alliance will also take into account other times of high traffic such as the Christmas Holidays and make efforts using it's Delivery Management System, Voyage Control, to reduce impact during high usage times as far as reasonably practicable. In addition to our efforts, to achieve efficiency of the works delivery our supply chain partners will in general try to avoid busy traffic periods so that they get better utilisation from their plant and equipment.
- 4.4.4 Upon arrival to each compound, all deliveries will report to the security/gateman. This will be communicated to all suppliers and subcontractors at their pre-start meetings and via Voyage Control.
- 4.4.5 The access points will be designed to ensure that no vehicle entering the site is restricted (other than abnormal loads, if required). Suitable space within the works site will be provided for all vehicles to park, unload and manoeuvre, therefore enabling all egressing vehicles to exit onto the access road in a forward-facing direction. Reversing onto any public highway will not be permitted.
- 4.4.6 On the approach to and on-site, the delivery operation will be controlled by a trained SIA/CITB gateman from the point of guiding a vehicle to its designated off-loading area to guiding the vehicle back onto the public highway. Both the gateman and drivers will be expected to know, understand and put into practice the relevant safety procedures and correct signalling systems.
- 4.4.7 For construction traffic:
- No delivery vehicles are to reverse without the direction of a gateman; etc.
 - Flashing Beacons or Hazard lights must be in use at all times.
 - Seat belts must be worn at all times.
 - Appropriate PPE must be worn when alighting the vehicle.
- 4.4.8 Mud and debris on the local highway network will be kept to a minimum. The surface at the access point will be treated appropriately; this will involve track stoning, repairing potholes and / or reinstating any worn areas.
- 4.4.9 All parking areas will be constructed with hard surfacing. This will ensure that vehicles entering and exiting site are not required to use worn surfaces whereby mud and debris can accumulate and be transported off site and onto the public highway.
- 4.4.10 All vehicles working within the site that accumulate mud and debris will not be permitted to exit the site until they have been sufficiently washed down on site. Wheel washing and inspection facilities will be

provided to ensure the wheels and wheel arches are clean and clear of debris before the vehicle exits onto the public highway. In addition, there will be a road sweep on call at all times should cleaning of the public highway be required.

- 4.4.11 If during the winter months, any grit is removed as a result of these washing and sweeping measures, EWR will ensure that all grit will be suitably replaced.

4.5 Vehicle identification

- 4.5.1 Full-time and site-based vehicles will have Alliance livery so that they are identifiable as part of the Project.
- 4.5.2 Vehicles making deliveries on behalf of third-party suppliers will not have Alliance livery as it is not practical. However, as explained above, each supplier will be required to book deliveries to a construction compound via Voyage Control to allow adequate control, tracking and identification of delivery vehicles.

4.6 Vehicle types

HGVs

- 4.6.1 Any vehicle over 7.5t is considered an HGV. For the movement of bulky or large materials, these are likely to be predominantly 40t 4-axle wagons, as shown in **Figure 4-1**, but may also include some other vehicles; such as 40ft articulated lorries, low loaders delivering plant materials and extendable trailers delivering Pre-Cast Concrete elements.

Figure 4-1 Drawing of a typical 40t 4-axle wagon, used for granular materials

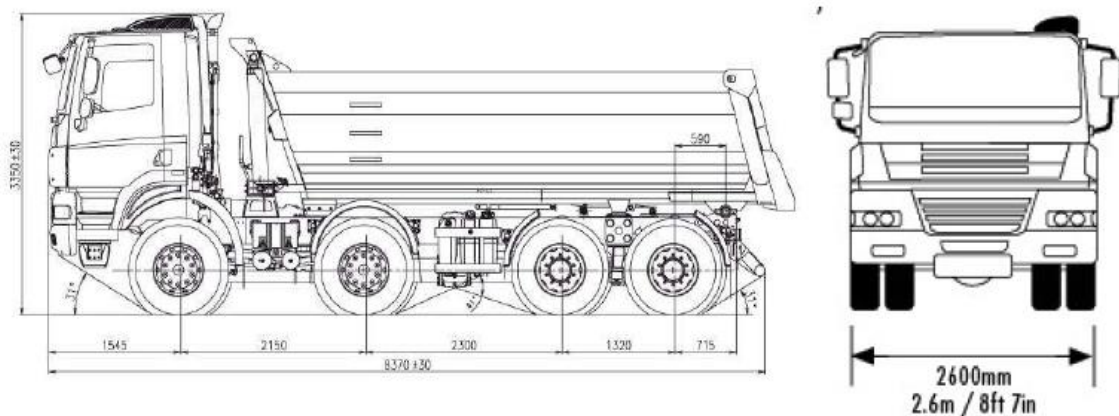

LGVs

- 4.6.2 Any vehicle up to 7.5t excluding cars is considered an LGV. These vehicles will predominantly be 3.5t and 5t rigid pickups with droppable sides and crew cabs, as shown in **Figure 4-2**, and will be used to move small plant and materials around site. Other LGVs will include long and short wheelbase vans and the minibuses used to transport construction personnel between construction compounds and public transport hubs (at certain sites).

Other vehicles

- 4.6.3 Other vehicles to be used include 50T-70T mobile cranes which vary in size but are generally suited for most typical roads.

Figure 4-2 Drawing of a typical 5t rigid pickup

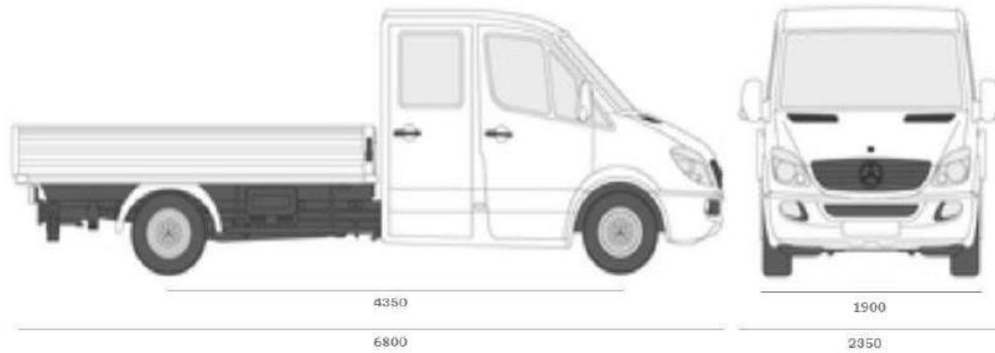

5. Public rights of way

5.1 Overview

Closure and notification process

- 5.1.1 Any Public Right of Way (PROW) that is directly affected due to construction works will be closed or managed via the Electronic Transfer of Notice (ETON) process that Network Rail have already in place across the country with all Local Highways Authorities.

Figure 5-1 The ETON process

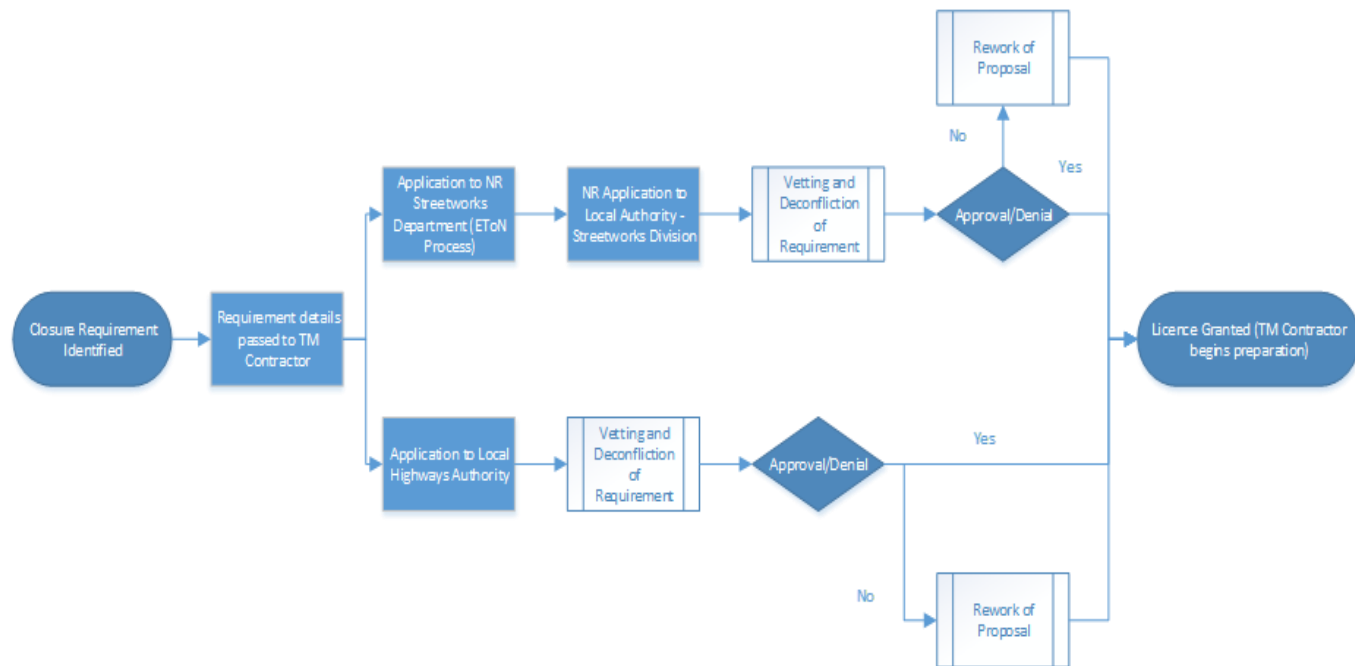

- 5.1.2 Any PROW identified for closure will remain closed only for the minimum duration required to ensure that there is no hazard to the general public. Close coordination with the relevant local highway authority will be maintained to ensure that the local community is adequately warned of impending closures and, where appropriate, mitigating measures are in place. This should include the positioning and maintenance of 'advance warning' notices at agreed points on the rights of way network to indicate where the route is closed ahead and also show an alternative route if one is available.

- 5.1.3 An indicative list of closures is available at Appendix B which will be regularly updated and shared with the LHA.

Management strategy

A PROW Management Strategy plan will be provided which will include the treatment of PROWs and permissive paths post construction. This will clearly state how, following completion of the construction works, all PROWs will be returned to their pre-construction state as a minimum. As part of this Management Strategy, there will be close liaison with the relevant Highway Authority, however this communication is independent of the Planning Conditions. A pre-construction survey will be undertaken by the Alliance land agent Bruton Knowles to determine baseline conditions and, post-construction, a review will be carried out to ensure that adequate reinstatement has been implemented.

6. Traffic management

6.1 Traffic management principles

- 6.1.1 Access points will use wide bell mouth entryways. This will necessitate traffic management for both normal users of the highway and construction traffic accessing and egressing the access point.
- 6.1.2 The Alliance will use a specialist traffic management contractor to ensure appropriate standards are implemented and maintained. The guiding principles for traffic management activities is first health and safety for all construction personnel and secondly the minimisation of inconvenience to the general public.
- 6.1.3 Basic communication requirements of all CTMPs will be to provide:
- Advanced warning of changes to the public highway to enable drivers to adjust their driving accordingly.
 - Clear information and guidance as to how to safely negotiate the work site; this includes the delineation of travel paths and their separation from the work site with barricading as required.
- 6.1.4 VMS systems will be provided at major road junctions as appropriate to the EWRA programme. These systems will be moveable to reflect the changing nature of works and concentrations of effort along the route. VMS systems positioned at compound entrances will be maintained for the duration of peak construction works in order to forewarn other road users of potential delays or hazards.
- 6.1.5 The contact details for VMS signs will be submitted to the LHA during their use. The emplacement of VMS signs will be agreed mutually with the LHA prior to emplacement and/or movement. This is to ensure no clash with other VMS in the near vicinity occurs that could lead to misdirection of the public.
- 6.1.6 Typical signage and barriers used in temporary traffic management include the examples shown in **Figure 6-1**. It may also be required to use temporary traffic lights or to apply a temporary reduction to the normal speed limit. For all these activities, the same ETON process as used for PROW will be used to secure permission and to enable close liaison, and ongoing communication and coordination with the relevant local highway authorities.

Figure 6-1 Typical temporary traffic management signage and barrier examples



6.2 Road control principles

- 6.2.1 **Figure 6-2** illustrates a typical road works control layout plan for a generic work site. The Alliance's Senior Construction Manager / Works Foreman shall ensure that the components which are relevant to their specific work site are identified and the appropriate traffic management scheme is applied.

Figure 6-2 Typical road works control layout plan

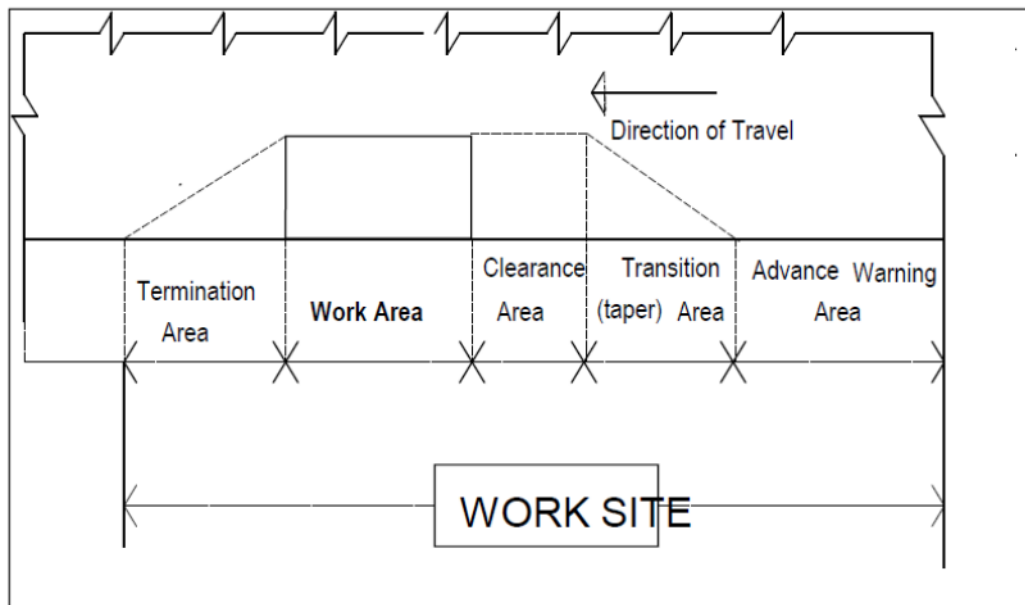

Approach taper partially closed lane

- 6.2.2 If a roadway is required to be partially closed, an appropriate taper will be marked in the transition area and, wherever possible, shall be located so that its full length is visible to approaching traffic.
- 6.2.3 Traffic cones or bollards are used after the appropriate advance signs on the approach side of the hazard, forming a taper from the kerb to the outer limits of the clearance area. **Table 6.1** provides a guide to the recommended taper length for two-lane, two-way roads to be closed for various approach speeds based on a lane width of 3.5m.

Table 6.1: Summary of recommended taper lengths

Recommended taper length			
Approx. approach speed	Traffic control at beginning of taper	Diverge taper	Merge taper
Less than 60 km/h **	15 m	15 m	30 m
60 to 80 km/h	30 m	70 m	140 m
81 to 100 km/h	30 m	90 m	180 m
More than 100 km/h	30 m	100 m	200 m

** - Typical on low speed residential or commercial street.

6.2.4 In regard to **Table 6.1**, the following should be noted:

- Traffic control at the beginning of a taper is applicable where this is a traffic controller just prior to a diverge, e.g. into a single lane.
- Diverge taper is applicable where traffic is simply required to shift laterally without conflict with another stream of traffic.
- Merge taper is applicable where one lane of traffic is required to merge onto another lane of traffic.

Delineation at work site - travel paths

6.2.5 To provide suitable, adequate and appropriate guidance for road users, traffic control measures shall provide details for both short and long-range travel paths. Long-range delineation provides drivers with an advance view of the site, indicating the general direction of the trafficable path, whereby short-range delineation guides the driver through the works once they have entered. Depending on the circumstances, movement of traffic in connection with a work site shall be achieved in one of the following ways:

- Through the Work Area.
- Past the Work Area.
- Around the Work Area by a detour which may be via a side track or an existing road.

Through the Work Area

6.2.6 Unless there is no practicable alternative, passage through a Work Area shall only be considered on lightly trafficked roads and where traffic and works can be adequately controlled so that the risk to any site operatives and traffic is kept as low as possible.

Past the Work Area

6.2.7 Where traffic is conducted past the Work Area there needs to be a minimum distance of 1.2m clearance between the edge of the Work Area and the edge of the travel path as a no-go buffer zone. This clearance shall be defined on both sides of the travel path to avoid inadvertent intrusion by any persons and shall be provided by the use of containment fences such as barrier tapes, mesh fences, interconnected lightweight units or bollard fences.

Around the Work Area

6.2.8 When it is not practical to allow traffic through or past the Work Area it may be catered for by means of either a diversion using existing roads or a specially constructed track. This practice, in general, would require advice and permission from the relevant highway authority.

7. Signage principles

7.1 Principles of signage

7.1.1 The Alliance's Senior Construction Manager / Works Foreman shall ensure the following principles are applied regarding signage:

- Signs and devices comply with those listed in Traffic Signs Manual Chapter 8, Parts 1 and 2.
- Signs and devices will be erected and displayed before work commences.
- On approaches to the Work Area signs are erected in the following sequence and then removed in the reverse order.
- Advance warning signs.
- Other warning signs.
- Instruction signs
- Signs are placed within the driver's line of sight and at the same time not obscuring other traffic devices from the driver's line of sight.
- All signs and devices are placed in the most advantageous positions, considering the location and nature of hazard and the warning being conveyed, to provide the maximum visual impact for approaching traffic. Such signs and devices shall have an adequate clear view in advance of them (e.g. a minimum of 50m for 60 km/h and a minimum of 100m for 100 km/h).
- Signs and devices are placed in a manner and position so they are not obscured from view by vegetation, parked vehicles or any other visual obstruction.
- Signs and devices are placed in a manner and position so as not to become a possible hazard to construction personnel, pedestrians or vehicles (e.g. diverting traffic into an undesirable path).
- Signs and devices shall be regularly checked for effectiveness and maintained in a satisfactory condition.
- Signs and devices are selected and placed in a manner so as not to require a driver to disobey a law unless so directed by an authorised officer, such as a police officer.
- Permanent signs which conflict with the signs required for the temporary work situation are covered or removed.
- Signs and devices are removed from the site when practical and once the hazard ceases to exist, resoring the road/footway to previous condition.
- Original signage is uncovered or reinstalled returning the signs to their original state as a minimum.
- Any temporary signage associated with the Construction Access Routes will be removed when the EWR works have been completed.

7.1.2 The Alliance's Senior Construction Manager / Works Foreman shall ensure careful consideration is given to signage of the site to:

- Provide advance warnings to drivers of changes in the surface of the roadway, and/or any changes in the traffic conditions, and that personnel are engaged in work.
- Adequately instruct and guide traffic safely through, past or around the work site.
- Provide separation of the travel path and the works area.

7.2 Erection and location of signs

7.2.1 EWRA's Senior Construction Manager / Works Foreman shall ensure:

- All road signs are used with approved stands or erected on posts set into the ground (where permitted by the relevant authorities).
- Where signs are erected on posts set into the ground the following applies:
- On un-kerbed roads in both rural and urban areas the sign should be at least 600mm clear of the outer edge of the road shoulder, line of guide posts or face of the guard measured towards the property boundary. The clearance should not be less than 1m nor more than 5m from the edge of the running lane and the height of the sign should be 1.5m above the nearest edge of the running lane.
- On kerbed roads, signs should be located back from the face of the kerb, no less than 300mm and no more than 1.0m. The height of the sign should be approximately 2.2m above the kerb or footway to reduce the interference from parked cars.
- Where the signs are erected on temporary stands for short term work they should be erected on the road shoulder in un-kerbed areas no closer than 600mm to the running lane. In kerbed areas the provisions outlined above for post-mounted signs shall be followed.

7.3 Advance and intermediate advance warning signs

7.3.1 Advance and intermediate advance warning signs will alert approaching vehicles of changes to road conditions, enabling road users to negotiate any travel path at an acceptable level of risk.

7.3.2 For the purposes of the Project, the advance warning signs are limited to:

- Workers ahead
- Roadwork ahead
- Site access ahead

7.3.3 Intermediate advance warning signs are used where, in addition to a general warning at the onset of the roadworks, another warning is required for a specific action or change of road condition.

7.3.4 The intermediate advance warning signs for the purposes of the Project are:

- Diversion ahead
- Prepare to stop

7.3.5 Advance warning signs for vehicular traffic are not required in the following situations:

- Whereby works are sufficiently remote from the roadway, meaning that no action or extra vigilance is required of a driver other than would be normally required on that section of road.
- Where approach speeds are so low that no devices are needed to provide advance warning; i.e. signs and devices can be seen in plenty of time for drivers to take necessary action.

7.4 Site access signage

7.4.1 Temporary signage will be installed to direct delivery vehicles to the compounds and access points via the designated Construction Access Routes.

7.4.2 Advanced temporary signage will be erected warning motorists and other highway users of site access points. All temporary signing strategies will be agreed with the relevant Highway Authorities prior to implementation.

7.5 Traffic controller's check

7.5.1 Traffic Controllers shall record that all the appropriate signs and traffic control requirements have been implemented according to the relevant Traffic Management Plan.

7.6 Termination taper

- 7.6.1 The termination taper indicates the end of the highway works. The use of three traffic cones or bollards will be used to create the taper with a typical spacing of 5.0 to 15.0m.

8. Delivery management

8.1 Overview

8.1.1 During the auditing and designation of the proposed Construction Access Routes, the Alliance has considered the following:

- Height and weight restrictions
- Road layout, where possible to avoid sensitive receptors (schools, churches, equestrian areas and areas of high pedestrian movements)
- Visibility constraints
- Restricted access
- Junctions at or near capacity during peak periods
- Road gradients

8.1.2 Feedback from the local communities and the relevant LHAs was also taken into consideration.

8.2 Audit and performance monitoring

8.2.1 It is planned that all of the logistics for the compound construction and subsequent works will be scheduled, routed and controlled via a delivery management system entitled 'Voyage Control'. This will allow for the precise routing of individual delivery loads and vehicles, clear time slot and prioritisation control, clear measurement of vendor compliance and performance tracking from source to destination.

8.2.2 The main benefit of using the Voyage Control system is the ability to respond rapidly to queries relating to:

- Routing
- Punctuality
- Sustainability performance
- Damage or complaints tracking by the public due to vehicle behaviour
- Removing / reducing conflict with other works in the same area
- Precise control of when and where individual loads will arrive with the associated ability to minimise and eliminate stacking of vehicles on the highway
- Maintenance of standards

8.2.3 Should any government organisation seek clarification on an incident or wish to glean information on performance, EWRA will be happy to provide a response or report to a reasonable expectation.

8.3 Communication and engagement

8.3.1 Drivers of construction / delivery vehicles can be directly contacted through the Voyage Control system, through legal telecommunications technology.

8.3.2 To ensure the suitability of the proposed Construction Access Routes, the Alliance will work closely with key stakeholders, aiming to minimise any disruption. These parties include LHA's, police and community organisations. The Alliance will also liaise with HS2 logistics teams throughout the project lifecycle to coordinate activity to reduce any impacts.

8.4 Movement of excavated materials and abnormal loads

- 8.4.1 Excavated materials will utilise the same Voyage Control system as deliveries, enabling the precise management of materials leaving the site.
- 8.4.2 Abnormal loads may be required to deviate from the Construction Access Route or to deliver outside the permitted working hours. All abnormal load deliveries in either of these circumstances, will require approval from the relevant local highway authority prior to accessing the construction compound or an access point.
- 8.4.3 Following legislation provided by the government, loads are considered 'abnormal' if they meet any of the following criteria:
- A weight of more than 44,000kg
 - An axle load of more than 10,000kg for a single non-driving axle and 11,500kg for a single driving axle
 - A width of more than 2.9 metres
 - A rigid length of more than 18.65 metres
- 8.4.4 In the eventuality of an abnormal load, the following parties will be given advance warning:
- The Police
 - Relevant highway authorities
 - Bridge and structure owners such as Network Rail
- 8.4.5 To comply with regulation, any abnormal loads will be organised via the Highways England ESDAL service (electronic service delivery for abnormal loads), or via the submission of a 'Abnormal load movement application form'. This will enable:
- Exact plotting of routes
 - Suitable notification to the police, Highways and Bridge Authorities of the abnormal load movements on the local highway network
 - Advance notice of any possible issues to the selected route
 - Storage of vehicle details and routes for future use

8.5 Movement of unscheduled loads

- 8.5.1 Any unscheduled deliveries (such as via UPS/FedEx/ or any other national couriers) that arrive on site will be processed immediately at the gate using an 'un-booked delivery' function. If an EWR vendor arrives at a gate with an unscheduled load, in the first instance they will be processed as an exception. Remedial actions and communications will then be communicated back to that vendor's dispatch to prevent any further errors. In the case of a second violation, the vehicle will be admitted and immediately turned around with the delivery being rejected and a penalty issued to the vendor. If repeated infractions occur, EWRA will take commercial action to mitigate the problem including dismissal.

Part B – Development Stage specific information

9. Development Stage and compound description

9.1 Compounds

- 9.1.1 Development Stage 2A1 contains one construction compound (Compound A1) located on Bicester Road, east of the A4421/Charbridge Lane/Bicester Road roundabout and north of the EWR trace. The location of Compound A1 is shown in Appendix C.
- 9.1.2 Further details of Compound A1 are provided in Section 12.
- 9.1.3 The proposed access to the construction compound is through via western perimeter off Bicester Road. More details on the access points are provided in Section 9.2 below and Construction Access Routes in Section 12.

9.2 Access points

- 9.2.1 The exact access and egress locations onto the public highway are known as access points and these form the final stage of each Construction Access Route.
- 9.2.2 As shown in Appendix C, there are 4 highway access points proposed as part of Development Stage 2A1. Development Stage 2A1 does not include any haul road crossings, passing places or off-site junction improvements.
- 9.2.3 The 3 access points and 2 haul road access point proposed as part of Development 2A1 are as follows:
- A1 Compound Access Point – provides the main access to compound A1. It is accessible via the Bicester Road through a priority junction.
 - A1_PA_9 – provides access to the EWR trace from the north. It is also accessible via the Bicester Road.
 - A1_TA_8 – provides additional access to compound A1.
 - HRA_0 – provides access to a haul road from the south. This point is not accessed from the public highway; however is accessible via Bidfood's private entrance which is already deemed suitable for HGV's. Bidfoods and the EWRA have worked collaboratively to design and agree this access point. Please see the following plans for reference:
 - Extendable Platform Vehicle_HRA0
 - HGV40t_HRA0
 - Max Legal_ HRA0
 - HRA00_VS_2
 - HRA_1 - provides access to Mill Meadow from Charbridge Lane for the construction of the Charbridge Lane diversion. This access point is an existing Network Rail Access point and there is no requirement to further improve the turnoff from the highway as the existing access is suitable for all vehicles as evidenced below. The existing shared use footpath will be managed during works using a gateman to ensure safety of public and staff. A further access point off the roundabout to the north of this point is not seen as necessary. Details of the access arrangements to construct the temporary diversion for necessary works are provided in the following drawings:
 - HRA1_Max Legal Articulated
 - HRA1_HGV40t
 - HRA01_VS

- 9.2.4 Appendix D provides a General Arrangement plan for the A1 Compound Access Point to demonstrate that the compound access can be used suitably. These plans include the following information:
- Carriageway width
 - Corner radii
 - Fencing
 - Gates; and
 - Visibility Splays
- 9.2.5 Please see the compound access drawings in Section 11.4 for reference.
- 9.2.6 General Arrangement plans for all other access points within development stage 2A1 have been transmitted as part of a wider highways improvements submission to the highway authority.

9.3 Haul road crossing points

- 9.3.1 There are no haul road crossing points in Development Stage 2A1.

9.4 Charbridge Lane developments

- 9.4.1 Charbridge Lane currently has an at-grade level crossing of the legacy train line. This is planned to be extinguished and a new bridge over the new railway will be provided. In order to provide this significant structure, it will be necessary to realign Charbridge lane several times onto localised routes so that construction can proceed. The sequencing and method by which these changes to traffic, road alignment and construction will take place will be developed in a collaborative manner with Oxfordshire authorities separately to the scope of this document.

9.5 Existing and Committed Developments

Overview

- 9.5.1 The Alliance are aware of other existing and committed developments close to Development Stage A1, and the potential implications that streams of unmanaged construction traffic could present to the local highway network. The Alliance will therefore endeavour to liaise with various stakeholders to manage the cumulative effects of construction traffic.

Existing Development

Charbridge Lane Allotments

- 9.5.2 Permanent impacts on community land use include the permanent land take of approximately 23% of allotment gardens on Charbridge Lane, Bicester. The allotment gardens are private land rented for allotments rather than allotments provided by the Council under their statutory obligation and located immediately south of the A4421/Bicester Road/ Charbridge Lane roundabout.

Launton Sports and Social Club

- 9.5.3 The Launton Sports and Social Club site will experience temporary land take during construction of the Project, extending into the access and parking areas. The site is located 450m (approx.) south east of the A4421/Bicester Road/ Charbridge Lane roundabout, utilising a priority junction access of Bicester Road.
- 9.5.4 The site is within the Otmoor Lowlands rural areas LCA, which has been assessed as experiencing moderate adverse and significant landscape effects during construction and year 1 of operation, reducing to non-significant slight adverse effects by year 15 of operation.

Residents of Station Cottage, Station Road, Launton

- 9.5.5 The curtilage of Station Cottage, Station Road, Launton will experience temporary land take during construction of the Project, reducing the area of usable outdoor space surrounding the house. The site is within the Oxfordshire Estate LCA, which has been assessed as experiencing moderate adverse and significant landscape effects during construction and year 1 of operation, reducing to non-significant slight adverse effects by year 15 of operation.

Tythe Barn

- 9.5.6 The Tythe Barn venue will gain a new access off Charbridge Lane.

9.6 Permitted Development

Land North of Skimmingdish Lane, Bicester (Id. No. CH1) (Application no. 15/01012/OUT)

- 9.6.1 This Reasonably Foreseeable Future Project (RFFP) is a planning application for 48,308sqm of employment floorspace (Class B1c, B2, B8 and ancillary B1a uses) on a site to the north of the railway corridor and north of Compound A1.

Gavray Drive, Bicester

- 9.6.2 This RFFP is a planning policy allocation for 300 dwellings and associated infrastructure, on a 23 ha. site to the south of the railway corridor and to the west of the Bicester ring road (A4421, Gavray Drive). This site was outlined in Policy Bicester 13 of the adopted Cherwell Local Plan 2011-2031.

HS2

- 9.6.3 The Alliance are conscious of the continued impacts of HS2 and the construction traffic associated with the two projects. The Alliance will therefore endeavour to liaise with HS2 in order to develop a close working relationship and coordinate construction traffic on the highway network.

10. Key personnel

- 10.1.1 The key personnel and their role in Development Stage 2A1 are listed below. The names of the site supervisor / foreman and gatemen will be confirmed by the Alliance's Senior Construction Manager at a later date, prior to the commencement of the works in Development Stage 2A1.

Management Team

- Section Delivery Lead: Mel Banks
- Construction CRE: Stuart Mckechnie
- H&S Adviser: Paul White
- Programme Logistics Manager: Adrian Iswariah
- Highways Project Manager: Rupert Dolman

Site Team

- Construction Manager: Ian Jolliff
- Section Logistics Manager: Wayne John
- Compound Security: Jules Wisom-Chew
- Supervisor / Foreman: Varies
- Gateman: Varies

- 10.1.2 Further details of the role and responsibilities of the management and site team are provided in Section 3.

11. Construction Access

11.1 Overview

- 11.1.1 The western boundary of Compound A1 lies approximately 2km east of Bicester town centre. The construction compound is proposed to be sited on agricultural land.
- 11.1.2 Construction vehicles will access Compound A1 through the western perimeter via the A1 Compound Access Point off Bicester Road, utilising a priority junction to manage traffic.

11.2 Access restrictions

- 11.2.1 All construction delivery vehicles accessing the local area from the wider strategic road network will use the designated Construction Access Routes and will be prohibited from using any other routes.
- 11.2.2 The Construction Access Routes have already been audited and approved to ensure suitable access to the site. A map showing these approved routes is provided in Appendix A.
- 11.2.3 In the event of an unexpected road closure or emergency, e.g. a vehicle collision, construction vehicles may be required to divert from the Construction Access Route. Within the areas surrounding the Project, numerous roads have been identified by the local highway authorities which construction vehicles are not permitted to use under any circumstances. In the case of Development Stage 2A1, no roads have been identified by the local highway authority.
- 11.2.4 Employees will also be encouraged to use the Construction Access Routes to access the site, however, it is not possible to prohibit employees from using other roads to and from the site when traveling in their own vehicle.
- 11.2.5 Construction deliveries are only permitted to access the site as follows:
 - Weekdays: between 07:00 and 18:00
 - Saturdays: between 10:00 and 16:00
 - Sundays: no deliveries permitted.
- 11.2.6 Any construction deliveries outside these times, such as abnormal loads, will require agreement from the relevant local highway authority.

11.3 Pre-condition survey

- 11.3.1 Condition 15a stipulates that pre-condition surveys of the existing highway network are to be undertaken for routes outlined for construction traffic, prior to the construction route becoming operational. An initial assessment was undertaken to identify which of the potential roads identified as Construction Access Routes would be most sensitive to increased construction traffic as a result of EWR works. Roads already designed to accommodate large volumes of vehicles (including HGV and LGV's), with existing high traffic flow levels e.g. 'A' Class roads, have been excluded from the scope of the pre-condition surveys due to the proportionately small impact that the addition of EWR traffic would have upon the route.
- 11.3.2 The appended condition survey and proposed schedule of work is provided for information (not approval) and is intended as the basis for the final agreement of condition and required works. The Project is committed to undertaking a combined walkout survey with the LHA to review the absolute latest condition of the highway and record current defects and agree the final scope of preventative works. This record must be completed by the EWR Alliance and approved by the LHA prior to commencement of works on any given highway intervention and prior to the construction route being brought into use for HGV traffic.

11.4 Highway improvement works

11.4.1 Table 14.1 lists all drawings applicable to Highways improvements made within Development Section 2A1. These drawings are submitted to the Local Highways Authority for approval via Appendix G. A pictorial representation of the location of the works can be viewed using Google Earth and the provided Keyhole Mark-up Language (kmz) file: OCC.kmz (extract image below)

Figure 11-1 Location of Highways Improvement Works in Development Section 2A1



Table 11.1: Overview of Highways Improvement Works Drawings

Document No.	Location	Title	Rev	Submission Date	Approval Date	Approval Certificate Number
133735_2A-EWR-OXD-CC_A1-DR-CH-003001	A1 Temporary Compound Access	A1 General Arrangement	B01.02	29/05/2020		133735_RW-EWR-XX-XX-RP-CH-000170
133735_2A-EWR-OXD-CC_A1-DR-CH-002003	A1 Temporary Compound Access	A1 Site Clearance	B01.04	29/05/2020		133735_RW-EWR-XX-XX-RP-CH-000170
133735_2A-EWR-OXD-CC_A1-DR-CH-002004	A1 Temporary Compound Access	A1 Existing Utilities	B01.05	29/05/2020		133735_RW-EWR-XX-XX-RP-CH-000170
133735_2A-EWR-OXD-CC_A1-DR-CH-002007	A1 Temporary Compound Access	A1 Road Plan and Profile	B01.03	29/05/2020		133735_RW-EWR-XX-XX-RP-CH-000170
133735_2A-EWR-OXD-CC_A1-DR-CH-002008	A1 Temporary Compound Access	A1 Existing and Proposed Contours	B01.04	29/05/2020		133735_RW-EWR-XX-XX-RP-CH-000170
133735_2A-EWR-OXD-CC_A1-DR-CH-002012	A1 Temporary Compound Access	A1 Street Lighting	B01.02	29/05/2020		133735_RW-EWR-XX-XX-RP-CH-000170
133735_2A-EWR-OXD-CC_A1-DR-CH-002019	A1 Temporary Compound Access	A1 Pavement Layout	B01.03.01	29/05/2020		133735_RW-EWR-XX-XX-RP-CH-000170
133735_2A-EWR-OXD-CC_A1-DR-CH-003002	A1 Temporary Compound Access	A1 Vehicle Swept Path Analysis (Sheet 1 of 3)	B01.01	29/05/2020		133735_RW-EWR-XX-XX-RP-CH-000170
133735_2A-EWR-OXD-CC_A1-DR-CH-003003	A1 Temporary Compound Access	A1 Vehicle Swept Path Analysis (Sheet 2 of 3)	B01.01	29/05/2020		133735_RW-EWR-XX-XX-RP-CH-000170
133735_2A-EWR-OXD-CC_A1-DR-CH-003004	A1 Temporary Compound Access	A1 Vehicle Swept Path Analysis (Sheet 3 of 3)	B01.01	29/05/2020		133735_RW-EWR-XX-XX-RP-CH-000170
133735_RW-EWR-XX-XX-RP-CH-000161	A1 Temporary Compound Access	A1 Departure from Standard	B01	29/05/2020		133735_RW-EWR-XX-XX-RP-CH-000170
133735_2A-EWR-OXD-A1_CA_6-DR-CH-010001	A1-CA-6 Permanent Compound Access	A1-CA-6 General Arrangement	B01.01	07/05/2020		133735_RW-EWR-XX-XX-RP-CH-000151
133735_2A-EWR-OXD-A1_CA_6-DR-CH-010002	A1-CA-6 Permanent Compound Access	A1-CA-6 Site Clearance	B01.01	07/05/2020		133735_RW-EWR-XX-XX-RP-CH-000151
133735_2A-EWR-OXD-A1_CA_6-DR-CH-010003	A1-CA-6 Permanent Compound Access	A1-CA-6 Existing Utilities	B01.01	07/05/2020		133735_RW-EWR-XX-XX-RP-CH-000151
133735_2A-EWR-OXD-A1_CA_6-DR-CH-010004	A1-CA-6 Permanent Compound Access	A1-CA-6 Road Plan and Profile	B01.01	07/05/2020		133735_RW-EWR-XX-XX-RP-CH-000151
133735_2A-EWR-OXD-A1_CA_6-DR-CH-010005	A1-CA-6 Permanent Compound Access	A1-CA-6 Existing and Proposed Contours	B01.01	07/05/2020		133735_RW-EWR-XX-XX-RP-CH-000151
133735_2A-EWR-OXD-A1_CA_6-DR-CH-010006	A1-CA-6 Permanent Compound Access	A1-CA-6 Vehicle Swept Path Analysis (Sheet 1 of 2)	B01.01	07/05/2020		133735_RW-EWR-XX-XX-RP-CH-000151
133735_2A-EWR-OXD-A1_CA_6-DR-CH-010007	A1-CA-6 Permanent Compound Access	A1-CA-6 Vehicle Swept Path Analysis (Sheet 2 of 2)	B01.01	07/05/2020		133735_RW-EWR-XX-XX-RP-CH-000151
133735_2A-EWR-OXD-A1_CA_6-DR-CH-010008	A1-CA-6 Permanent Compound Access	A1-CA-6 Visibility Splay (Sheet 1 of 2)	B01.02	07/05/2020		133735_RW-EWR-XX-XX-RP-CH-000151
133735_2A-EWR-OXD-A1_CA_6-DR-CH-010009	A1-CA-6 Permanent Compound Access	A1-CA-6 Visibility Splay (Sheet 2 of 2)	B01.01	07/05/2020		133735_RW-EWR-XX-XX-RP-CH-000151
133735_RW-EWR-XX-XX-RP-CH-000153	A1-CA-6 Permanent Compound Access	A1-CA-6 Departure from Standard	B01	10/06/2020		133735_RW-EWR-XX-XX-RP-CH-000168
133735_2A-EWR-OXD-A1_PA_7-DR-CH-010201	A1-PA-7 Permanent Allotment Access	A1-PA-7 General Arrangement	B01.01	07/05/2020		133735_RW-EWR-XX-XX-RP-CH-000151
133735_2A-EWR-OXD-A1_PA_7-DR-CH-010202	A1-PA-7 Permanent Allotment Access	A1-PA-7 Site Clearance	B01.01	07/05/2020		133735_RW-EWR-XX-XX-RP-CH-000151
133735_2A-EWR-OXD-A1_PA_7-DR-CH-010203	A1-PA-7 Permanent Allotment Access	A1-PA-7 Visibility Splay	B01.01	07/05/2020		133735_RW-EWR-XX-XX-RP-CH-000151
133735_2A-EWR-OXD-A1_PA_7-DR-CH-010204	A1-PA-7 Permanent Allotment Access	A1-PA-7 Road Plan and Profile	B01.01	07/05/2020		133735_RW-EWR-XX-XX-RP-CH-000151
133735_2A-EWR-OXD-A1_PA_7-DR-CH-010205	A1-PA-7 Permanent Allotment Access	A1-PA-7 Existing Utilities	B01.01	07/05/2020		133735_RW-EWR-XX-XX-RP-CH-000151
133735_2A-EWR-OXD-A1_PA_7-DR-CH-010206	A1-PA-7 Permanent Allotment Access	A1-PA-7 Vehicle Swept Path Analysis	B01.01	07/05/2020		133735_RW-EWR-XX-XX-RP-CH-000151
133735_2A-EWR-OXD-A1_PA_7-DR-CH-010207	A1-PA-7 Permanent Allotment Access	A1-PA-7 Cross Sections	B01.01	07/05/2020		133735_RW-EWR-XX-XX-RP-CH-000151
133735_RW-EWR-XX-XX-RP-CH-000108	A1-PA-7 Permanent Allotment Access	A1-PA-7 Departure from Standard	B01	10/06/2020		133735_RW-EWR-XX-XX-RP-CH-000168

12. Compound Details

12.1 Overview

- 12.1.1 The proposed location for Compound A1 is agricultural land adjacent to the EWR trace to the south and Bicester Road to the west. There are no buildings on the proposed site, however there are 2 trees close to the north-eastern boundary which is to be retained throughout the project and protected accordingly with fence panels.

12.2 Layout

- 12.2.1 A layout of Compound A1 is provided in Appendix F.
- 12.2.2 The site is generally level and bounded by agricultural land to the north and east, the EWR trace to the south and Bicester Road to the west.
- 12.2.3 The compound is accessible for construction traffic via the Compound Access Point off Bicester Road, providing a through route to the EWR trace towards the southeast of the site. The aforementioned through route includes a circular track for construction vehicles (one-way), enabling vehicles to access and egress from the site facing forward.

12.3 Parking

- 12.3.1 The compound has a car parking area to the north of the site with 175 allocated spaces.
- 12.3.2 An electric car charging point is located to the south of the cabin area adjacent to the car park, alongside a visitor/disabled parking area.
- 12.3.3 2 x bicycle shelters are also provided in the cabin area.

12.4 Operations

- 12.4.1 Construction vehicles will enter the site via the compound access point off Bicester Road, gaining access to the EWR trace, laydown and site storage areas utilising the designated internal route.
- 12.4.2 Please see the Traffic Management plans (Section 14) for additional details.
- 12.4.3 There are 2 main security points at the compound, each with designated security cabins, barriers and gates. These 2 points are located at the main compound access point off Bicester Road, and at the EWR trace access point to the southeast of the compound.
- 12.4.4 There are also 2 x single security gates for individual access and one security gate in front of the emergency entrance. All 3 additional gates are located to the north of the main entrance off Bicester Road.
- 12.4.5 A cabin area with 32 cabins is located south of the main car park area, in the centre of the site.

Turning, loading and off-loading area

- 12.4.6 Construction traffic will utilise a circular track throughout the compound enabling vehicles to enter and egress from the site facing forward. The circular route provides access from the Bicester Road to all laydown areas, storage areas in addition to the EWR trace. Vehicles accessing the compound or the EWR trace can turn at another location along the trace and exit the compound forward-facing if required.
- 12.4.7 Designated laydown and topsoil areas are located to the south of the site, with an additional small delivery bay located just to the north of the compound access point.

Management and handling of the movement of any excess excavated material and any new imported material

Overview

- 12.4.8 The management of any excess excavated material or any newly imported materials will utilise the same Voyage Control system as deliveries, enabling the precise management of materials leaving the site, as outlined in Section 8.4.
- 12.4.9 Materials taken off site will form part of the construction traffic and will be managed accordingly using the Voyage Control system, being taken to an appropriate processing facility.
- 12.4.10 For further information, please see associated Soil Management Plans for Compound A1, which has been submitted separately:
- 133735-EWR-REP-EEN-000205
 - 133735-EWR-REP-EEN-000206

12.5 Visitors

- 12.5.1 All construction vehicles planning to visit the site must be registered with the Voyager Control system. Compound A1 will be the main hub for all deliveries booked on the (DMS), with vehicle checks conducted with successful vehicles then sent to the correct Gate number. Any other visitors are required to sign in with security as per general site access arrangements outlined in Section A. A designated visitor/disabled parking area is located immediately south of the cabin area.

12.6 Site hoarding

- 12.6.1 The compound will utilise 2.4m paladin fencing on all elevations, with some areas inside the compound also erecting 1.8m paladin fencing to separate certain zones (such as the construction vehicle track and car parking areas). Please see the compound layout for further details.
- 12.6.2 Heras fence panels will also be erected around the 2x trees for protection.

12.7 Site storage

- 12.7.1 There is a site storage area, located near the centre of the construction compound, adjacent to the parking area. This includes:
- 2 x fuel storage
 - 1x site stores
 - 1 x site lab

12.8 Site specific control measures

- 12.8.1 Site specific control measures in place include:
- A wheel washing station will be positioned at the centre of the compound to prevent unwanted mud and debris leaving the site. The station is to be located on the return loop of the circular track route to ensure no construction vehicles can leave the site without clean wheels. Road sweepers will also be in operation to ensure no unwanted debris enters the local highway network.
 - Dust dampening and suppression techniques will also be used to limit the potential for unwanted dust. A monthly Dust Deposition and Flux Monitoring system will also be installed to measure potential dust arising from 'Trackout' activities. Please see associated Dust Management Plan and further details from the TWAO Environmental Statement.

13. Signage strategy

13.1 Overview

13.1.1 The signage strategy will follow the signage principles outlined in Chapter 7 and be in operation throughout the lifespan of the associated Construction Access Route/associated compound. Figure 13.1 indicates the areas and routes covered by this signage strategy, with each numbered inset a separate drawing ending in the inset number in Table 13.1 below.

Figure 13-1 2A1 Route Signage Strategy Geographical Extent

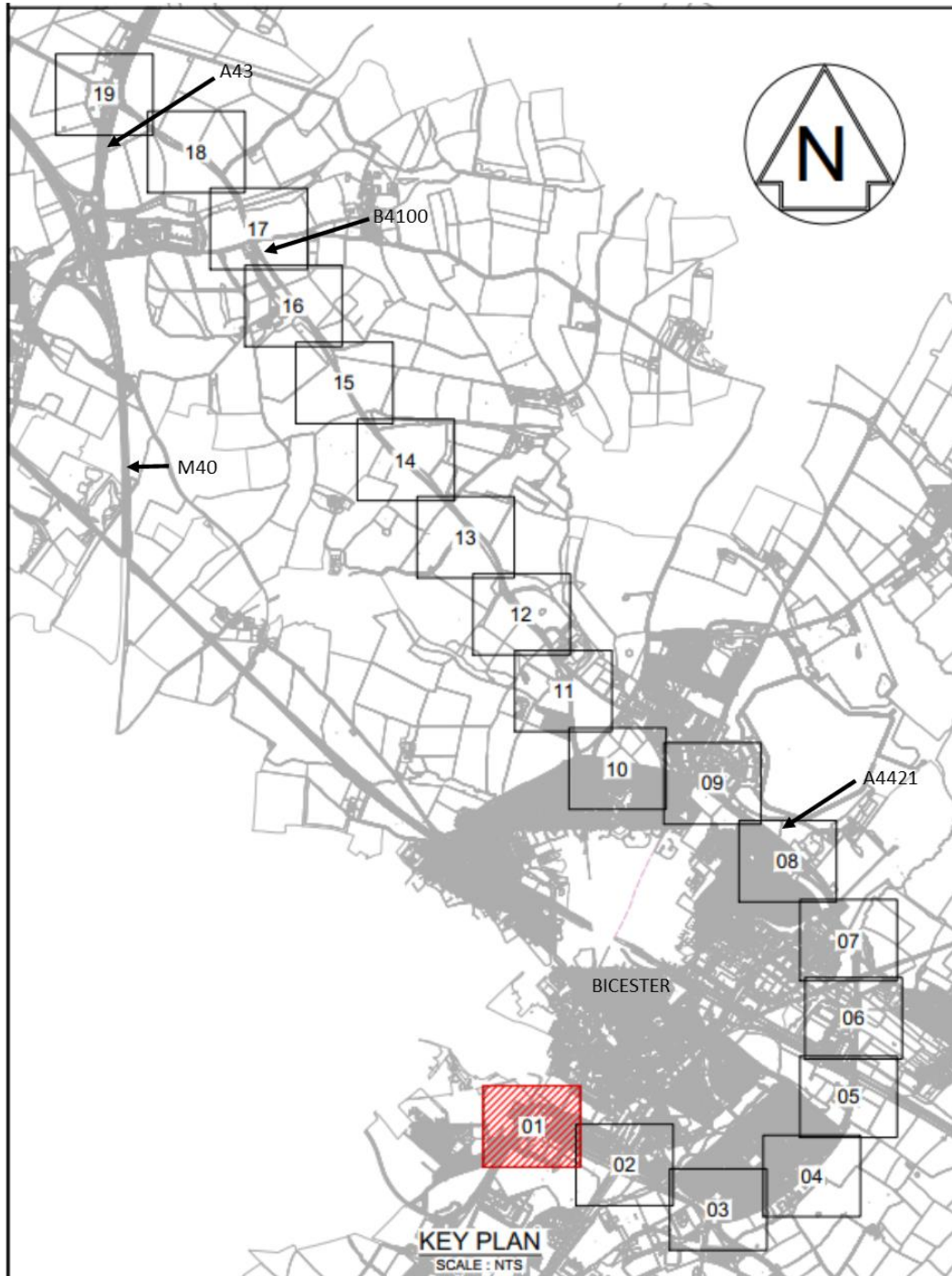

The signage strategy designs are contained within Appendix H, and are listed in Table 13.1. Drawing numbers 20 and 21 are not shown in the Key Plan at Figure 13.1 because they are schedules of materials.

Table 13.1: 2A1 Signage Strategy Drawings Submissions Register

Document No.	Rev	Submission Date
133735_RW-EWR-XX-CC_A1-DR-CH-010101	B01.01	03/03/2020
133735_RW-EWR-XX-CC_A1-DR-CH-010102	B01.01	03/03/2020
133735_RW-EWR-XX-CC_A1-DR-CH-010103	B01.01	03/03/2020
133735_RW-EWR-XX-CC_A1-DR-CH-010104	B01.01	03/03/2020
133735_RW-EWR-XX-CC_A1-DR-CH-010105	B01.01	03/03/2020
133735_RW-EWR-XX-CC_A1-DR-CH-010106	B01.01	03/03/2020
133735_RW-EWR-XX-CC_A1-DR-CH-010107	B01.02	01/06/2020
133735_RW-EWR-XX-CC_A1-DR-CH-010108	B01.01	03/03/2020
133735_RW-EWR-XX-CC_A1-DR-CH-010109	B01.01	03/03/2020
133735_RW-EWR-XX-CC_A1-DR-CH-010110	B01.01	03/03/2020
133735_RW-EWR-XX-CC_A1-DR-CH-010111	B01.01	03/03/2020
133735_RW-EWR-XX-CC_A1-DR-CH-010112	B01.01	03/03/2020
133735_RW-EWR-XX-CC_A1-DR-CH-010113	B01.01	03/03/2020
133735_RW-EWR-XX-CC_A1-DR-CH-010114	B01.01	03/03/2020
133735_RW-EWR-XX-CC_A1-DR-CH-010115	B01.01	03/03/2020
133735_RW-EWR-XX-CC_A1-DR-CH-010116	B01.01	03/03/2020
133735_RW-EWR-XX-CC_A1-DR-CH-010117	B01.01	03/03/2020
133735_RW-EWR-XX-CC_A1-DR-CH-010118	B01.01	03/03/2020
133735_RW-EWR-XX-CC_A1-DR-CH-010119	B01.01	03/03/2020
133735_RW-EWR-XX-CC_A1-DR-CH-010120	B01.03	01/06/2020
133735_RW-EWR-XX-CC_A1-DR-CH-010121	B01.05	01/06/2020

14. Traffic management

14.1 Overview

- 14.1.1 When construction personnel conduct works on the highway or public footway it creates an abnormal situation that requires the provision of traffic management measures (suitable signage, fencing/hoarding, guarding etc) to protect all public highway users and to minimise disruption.
- 14.1.2 Due to the complexity of works in development section 2A a full set of TM programmes, plans and drawings has been submitted. Please see the following submissions which are contained within Appendix I:

Table 14.1: 2A1 Traffic Management Drawings Submissions Register

Document No.	Rev	Submission Date
EWR2-2A-A1-0001	R1	03/03/2020
EWR2-2A-A1-0002	R1	03/03/2020
EWR2-2A-A1-0003	R2 R4	02/07/2020
EWR2-2A-A1-0004	R1	03/03/2020
EWR2-2A-A1-0005 P1	R1	03/03/2020
EWR2-2A-A1-0005 P2	R1	03/03/2020
EWR2-2A-A1-0005 P3	R1	03/03/2020
EWR2-2A-A1-0006	R2	01/06/2020
EWR2-2A-A1-0007	R2	01/06/2020
EWR2-2A-A1-0008	R1	03/03/2020
EWR2-2A-A1-0009	R1	03/03/2020
EWR2-2A-A1-0010 Pg1	R2 R3	02/07/2020
EWR2-2A-A1-0010 Pg2	R2 R3	02/07/2020
EWR2-2A-A1-0010 Pg3	R2 R3	02/07/2020
EWR2-2A-A1-0010 Pg4	R2	01/06/2020 Withdrawn
EWR2-2A-A1-0035	R1	03/03/2020
EWR2-2A-A1-0036	R2	01/06/2020
EWR2-2A-A1-0037	R2	01/06/2020
EWR2-2A-A1-0038	R1	03/03/2020

15. Public rights of way

15.1 Public rights of way overview

15.1.1 Due to the complexity of works in development section 2A1, a full PRow management plan separate to the required conditions will be submitted. Public Rights of Way design is a part of Condition 15b and is provided within this CTMP (Condition 15a) for informational purposes only. Please see the following designs submitted as files PRow 2A1 v3 and PRow Oxfordshire Standard Details v3 containing the following drawings:

Table 15.1: 2A1 PRow Design Drawings Submissions Register

Document No.	Rev	Submission Date
PRow 2A1 v3		
133735_2A-EWR-OXD-XX-DR-CH-000400	B01	08/06/2020
133735_2A-EWR-OXD-XX-DR-CH-000401	B01	08/06/2020
133735_2A-EWR-OXD-XX-DR-CH-000500	B01	08/06/2020
133735_2A-EWR-OXD-XX-DR-CH-000501	B01	08/06/2020
133735_2A-EWR-OXD-XX-DR-CH-000600	B01	08/06/2020
133735_2A-EWR-OXD-XX-DR-CH-000601	B01	08/06/2020
PRow Oxfordshire Standard Details v3		
133735_RW-EWR-XX-XX-DR-CH-000141	B01	08/06/2020
133735_RW-EWR-XX-XX-DR-CH-000144	B01	08/06/2020
133735_RW-EWR-XX-XX-DR-CH-000207	B01	08/06/2020
133735_RW-EWR-XX-XX-DR-CH-000224	P01	08/06/2020
133735_RW-EWR-XX-XX-DR-CH-000225 rev P01	P01	08/06/2020
133735_RW-EWR-XX-XX-DR-CH-000226 rev P01	P01	08/06/2020
133735_RW-EWR-XX-XX-DR-CH-000227 rev B01	B01	08/06/2020

15.1.2 In addition to the PRow designs listed above maps showing the proposed closures as well as footpaths still available for the public to use have been developed under the guidance of the LHA's PRow officer Sarah Aldous. These drawings are provided for information purposes and do not form part of the design approval within Condition 15b. These may be found within the following submission:

- PRow Closures – Jarvis Lane to Station Road

Appendices

Appendix A. Construction Access Routes

Appendix B. Indicative Roadspace and PRow Booking Schedule

Appendix C. Development Stage Layout

Appendix D. General Arrangement Plans

Appendix E. Pre-Commencement Survey

Appendix F. Compound Layout

Appendix G. Offline Highways Improvement Works

Appendix H. Construction Route Signage Strategy

Appendix I. Traffic Management Drawings

Appendix I updated 2/7/20 with changes to 4 drawings as show in table 14.1, following comments from OCC.